



US006918816B2

(12) **United States Patent**  
**Bianchi**

(10) **Patent No.:** **US 6,918,816 B2**  
(45) **Date of Patent:** **Jul. 19, 2005**

(54) **APPARATUS AND METHOD FOR  
POLISHING A FIBER OPTIC CONNECTOR**

- (75) Inventor: **Robert J. Bianchi**, Minneapolis, MN (US)
- (73) Assignee: **ADC Telecommunications, Inc.**, Eden Prairie, MN (US)
- (\* ) Notice: Subject to any disclaimer, the term of this patent is extended or adjusted under 35 U.S.C. 154(b) by 0 days.

- (21) Appl. No.: **10/356,358**
- (22) Filed: **Jan. 31, 2003**
- (65) **Prior Publication Data**  
US 2004/0152399 A1 Aug. 5, 2004

- (51) **Int. Cl.<sup>7</sup>** ..... **B24B 49/00**
- (52) **U.S. Cl.** ..... **451/11; 451/168; 451/173**
- (58) **Field of Search** ..... 451/11, 168, 170,  
451/171, 173, 312, 313, 317

- (56) **References Cited**  
**U.S. PATENT DOCUMENTS**  
2,577,312 A 12/1951 Donahue  
3,868,794 A 3/1975 Zitkus  
4,291,502 A 9/1981 Grimsby et al.

(Continued)

- FOREIGN PATENT DOCUMENTS**  
DE 40 04 665 A1 8/1991  
DE 197 52 228 A1 5/1998  
EP 0 579 056 A1 1/1994

(Continued)

**OTHER PUBLICATIONS**

- “ADC FasTerm™ Multimode LX.5™ Connector Installation Instructions,” *ADC Telecommunications, Inc.*, Issue 2, pp. 1–25 (Apr. 2001).
- “Universal Type 12–Axis Optical Fiber Polisher SFP–510,” *JPS Optics Inc.*, 4 pages (1989).
- “ADC FasTerm® Singlemode UPC and Multimode LX.5® Connector Installation Instructions,” *ADC Telecommunications, Inc.*, Issue 2, pp. 1–26 (May 2002).
- “Fiber Optic,” *Nanometer Technologies*, 1 page (visited May 24, 2004).

(Continued)

*Primary Examiner*—M. Rachuba  
(74) *Attorney, Agent, or Firm*—Merchant & Gould P.C.

(57) **ABSTRACT**

A fiber optic polishing apparatus including a support system, a polishing sub-assembly coupled to the support system including a plurality of pads, and a fixture to hold a plurality of fiber optic connectors. The fixture is positioned adjacent to the plurality of pads so that an end surface of each of the plurality of fiber optic connectors is held in contact with a corresponding pad. A drive mechanism is coupled to the support system to move the fixture to polish the end surface of each of the plurality of fiber optic connectors. Each of the plurality of pads may travel independently in a vertical direction. The polishing sub-assembly may further include a web polishing film, a fluid injection module configured to direct water onto the film, and a rinsing module to rub against a face of each of the plurality of fiber optic connectors to remove debris.

**15 Claims, 42 Drawing Sheets**

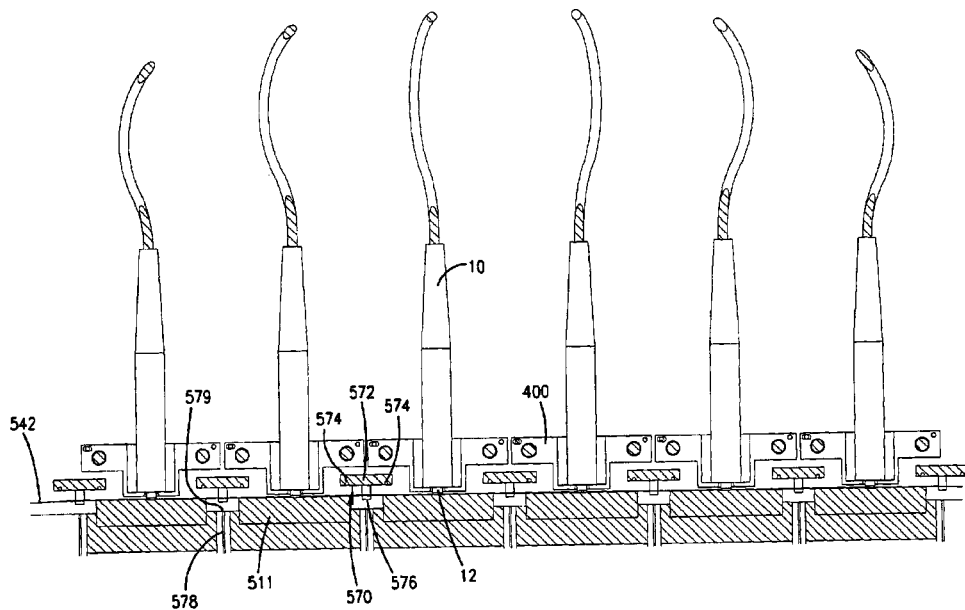

U.S. PATENT DOCUMENTS

4,498,260 A 2/1985 Doty  
 4,587,768 A 5/1986 Doyle  
 4,649,670 A 3/1987 Snyder  
 4,693,035 A 9/1987 Doyle  
 4,709,512 A 12/1987 Okubo et al.  
 4,802,680 A 2/1989 Fuchs  
 4,819,386 A 4/1989 Struyf  
 4,831,784 A 5/1989 Takahashi  
 4,850,152 A 7/1989 Heynacher et al.  
 4,891,916 A 1/1990 Rhoades et al.  
 4,905,415 A \* 3/1990 Moulin ..... 451/276  
 4,979,334 A 12/1990 Takahashi  
 5,107,627 A 4/1992 Mock, Jr. et al.  
 5,136,820 A 8/1992 Luther  
 5,184,433 A 2/1993 Maack  
 5,201,148 A 4/1993 Rupert et al.  
 5,216,846 A 6/1993 Takahashi  
 5,218,786 A 6/1993 Takahashi  
 5,265,381 A 11/1993 Takahashi  
 5,281,884 A 1/1994 Basavanhally et al.  
 5,321,917 A 6/1994 Franklin et al.  
 5,345,323 A 9/1994 Basavanhally et al.  
 5,349,784 A 9/1994 Grois et al.  
 5,351,445 A 10/1994 Takahashi  
 5,403,227 A \* 4/1995 Franklin et al. .... 451/168  
 5,447,464 A 9/1995 Franklin et al.  
 5,458,528 A 10/1995 Lurie et al.  
 5,458,531 A 10/1995 Matsuoka et al.  
 5,461,689 A 10/1995 Matsuoka et al.  
 5,516,328 A 5/1996 Kawada  
 5,547,418 A 8/1996 Takahashi  
 5,556,323 A 9/1996 Luther et al.  
 5,559,916 A 9/1996 Terao et al.  
 5,601,474 A 2/1997 Takahashi  
 5,643,064 A 7/1997 Grinderslev et al.  
 5,667,426 A 9/1997 Minami et al.  
 5,674,114 A 10/1997 Miller et al.  
 5,711,701 A 1/1998 Grinderslev et al.  
 5,720,653 A 2/1998 Miller et al.  
 5,741,171 A 4/1998 Sarfaty et al.  
 5,743,787 A 4/1998 Ishiyama et al.  
 5,778,125 A \* 7/1998 Busse et al. .... 385/80  
 5,813,902 A 9/1998 Wiegand  
 5,947,797 A 9/1999 Buzzetti  
 6,077,154 A 6/2000 Takashi et al.  
 6,106,368 A 8/2000 Childers et al.  
 6,110,013 A 8/2000 Minami et al.  
 6,113,469 A 9/2000 Yoshikawa et al.

6,126,519 A 10/2000 Minami et al.  
 6,157,863 A 12/2000 Chandler et al.  
 6,165,055 A 12/2000 Takahashi et al.  
 6,183,343 B1 2/2001 Buzzetti  
 6,190,239 B1 2/2001 Buzzetti  
 6,257,971 B1 7/2001 Takahashi et al.  
 6,276,842 B1 8/2001 Xu et al.  
 6,280,293 B1 8/2001 Minami et al.  
 6,302,763 B1 10/2001 Buzzetti  
 6,347,974 B1 2/2002 Chandler et al.  
 6,396,996 B1 5/2002 Carpenter et al.  
 6,641,472 B2 \* 11/2003 Boyer et al. .... 451/526  
 6,752,536 B2 \* 6/2004 Boyer et al. .... 385/60  
 2001/0023164 A1 9/2001 Minami et al.  
 2002/0160700 A1 10/2002 Boyer et al.

FOREIGN PATENT DOCUMENTS

EP 0 621 107 A1 10/1994  
 JP 59-161256 9/1984  
 JP 60-217055 10/1985  
 JP 61-113005 5/1986  
 JP 63-283854 11/1988  
 JP 63-316811 12/1988  
 JP 5-19140 1/1993  
 JP 5-157941 6/1993  
 JP 5-164942 6/1993  
 JP 6-138343 5/1994  
 SU 738825 6/1980

OTHER PUBLICATIONS

“MCP 24 Advantages and Specs,” *Nanometer Technologies*, 1 page (visited May 24, 2004).  
 “MCP 24 Figure 8 Polishing,” *Nanometer Technologies*, 1 page (visited May 24, 2004).  
 “MCP 24 Fixture Plates,” *Nanometer Technologies*, 1 page (visited May 24, 2004).  
 “MCP 24 Fixture Plates,” *Nanometer Technologies*, 1 page (2004).  
 “MCP 24 Mass Connector Polisher,” *Nanometer Technologies*, 1 page (2004).  
 “MCP 24 Mass Connector Polisher—Technical Information,” *Nanometer Technologies*, 1 page (2004).  
 “MCP 24 Universal Polishing Fixture,” *Nanometer Technologies*, 1 page (visited May 24, 2004).  
 “SFP-550,” *Seikoh Giken USA*, 2 pages (2004).

\* cited by examiner

FIG. 1  
(Prior Art)

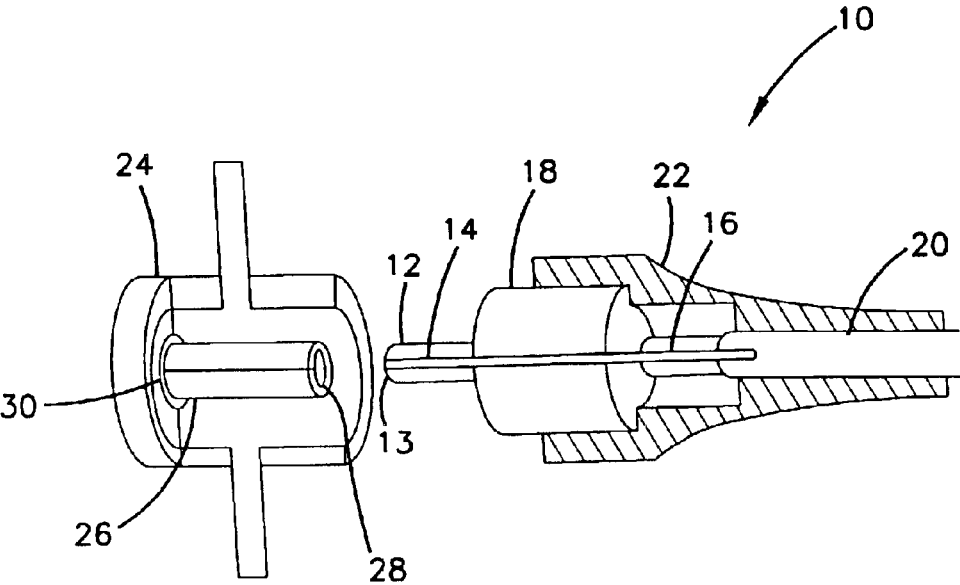
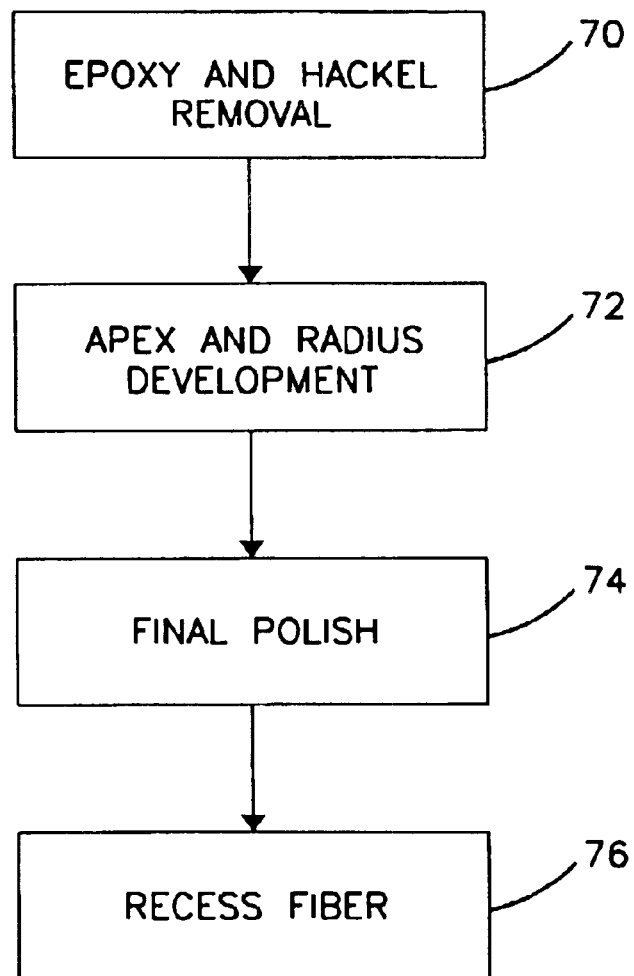

FIG. 2  
(Prior Art)



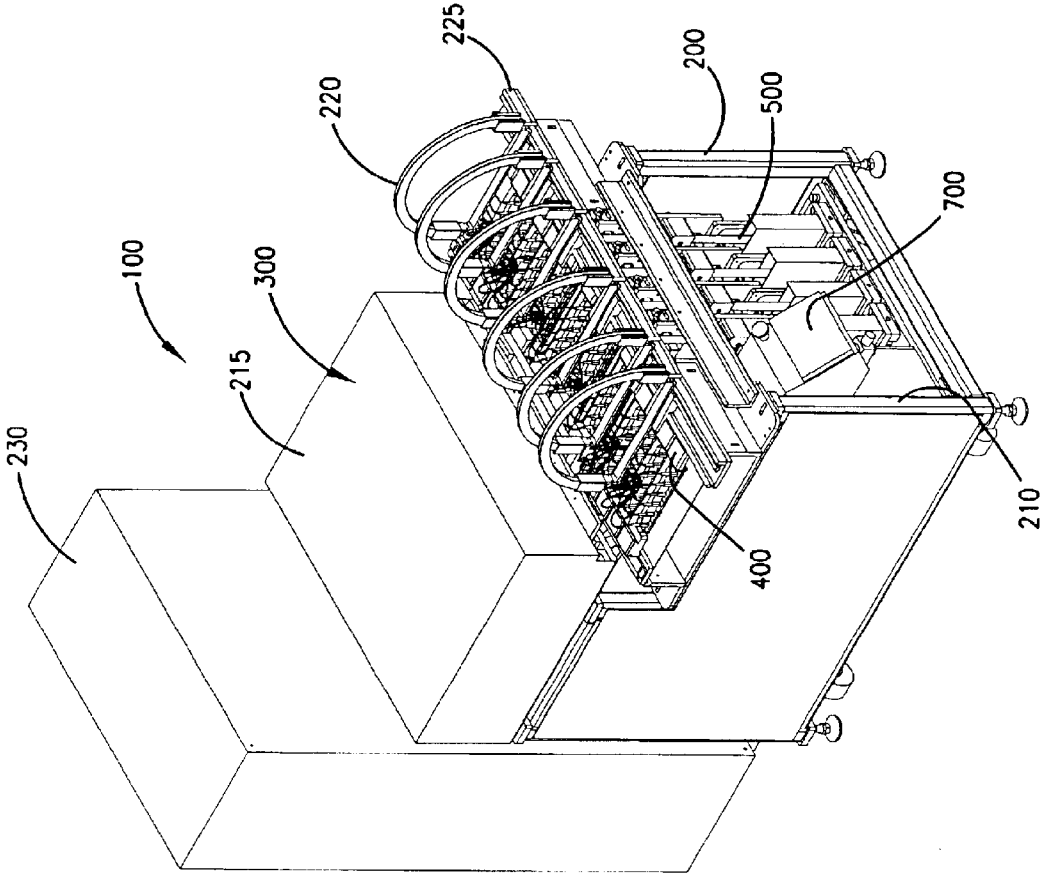

FIG. 3

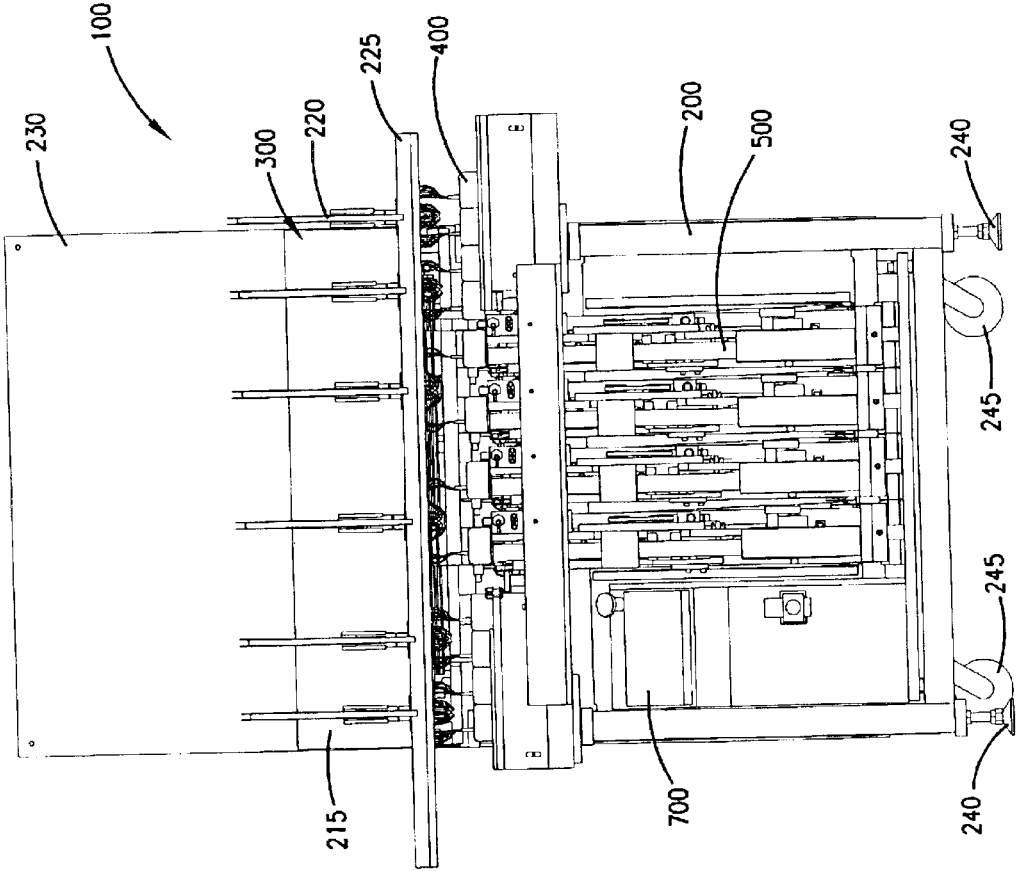

FIG. 4

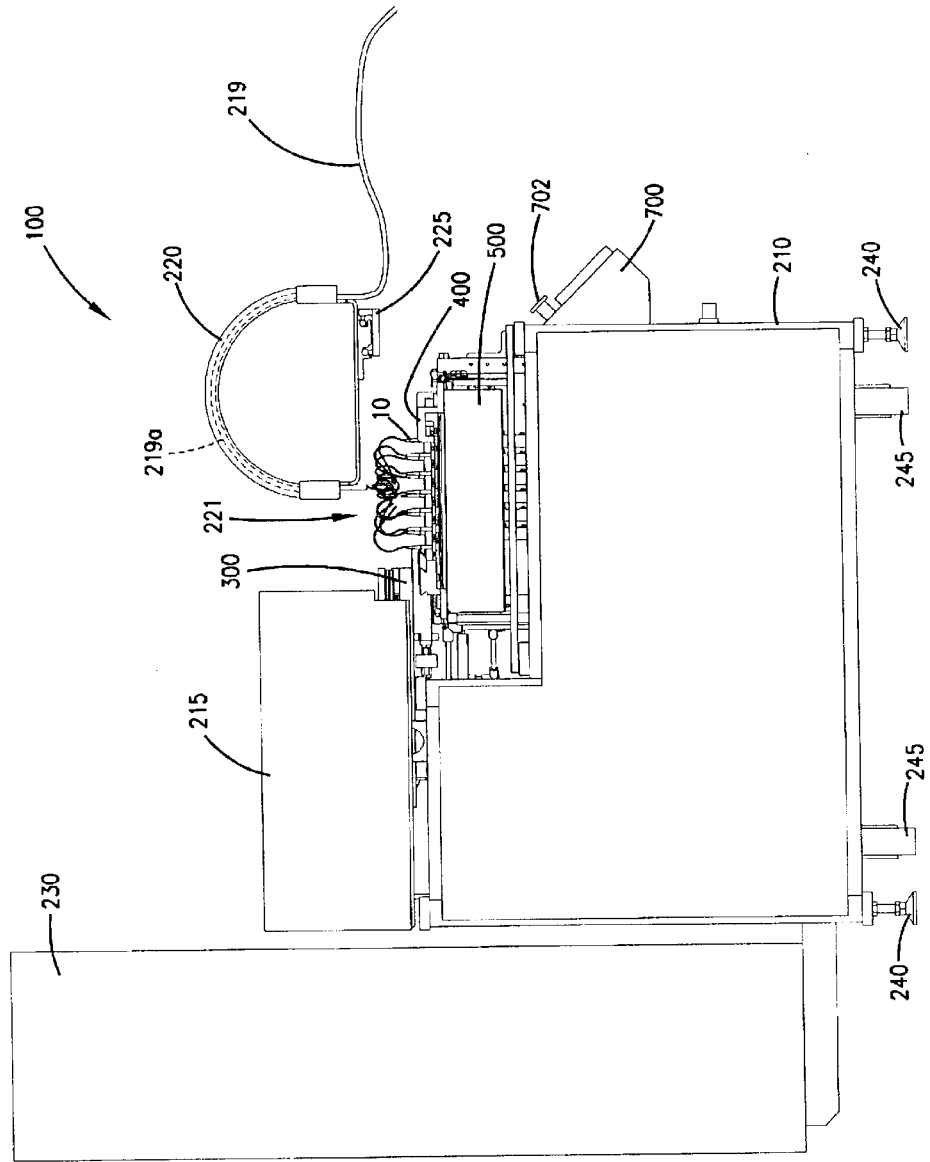

FIG. 5

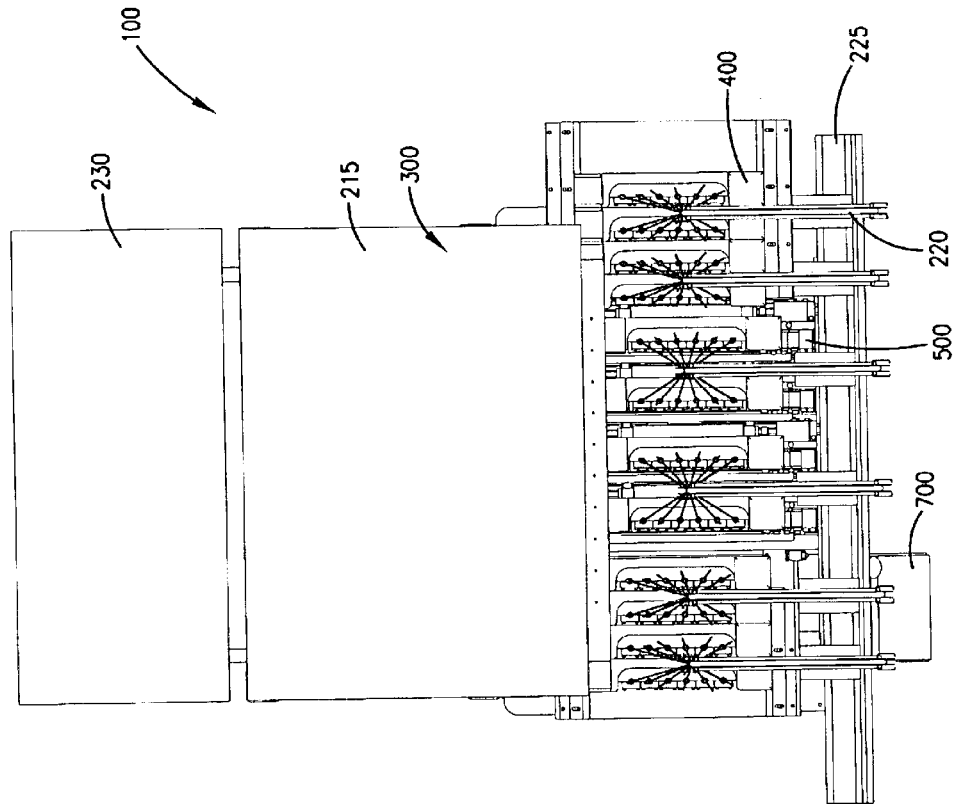

FIG. 6



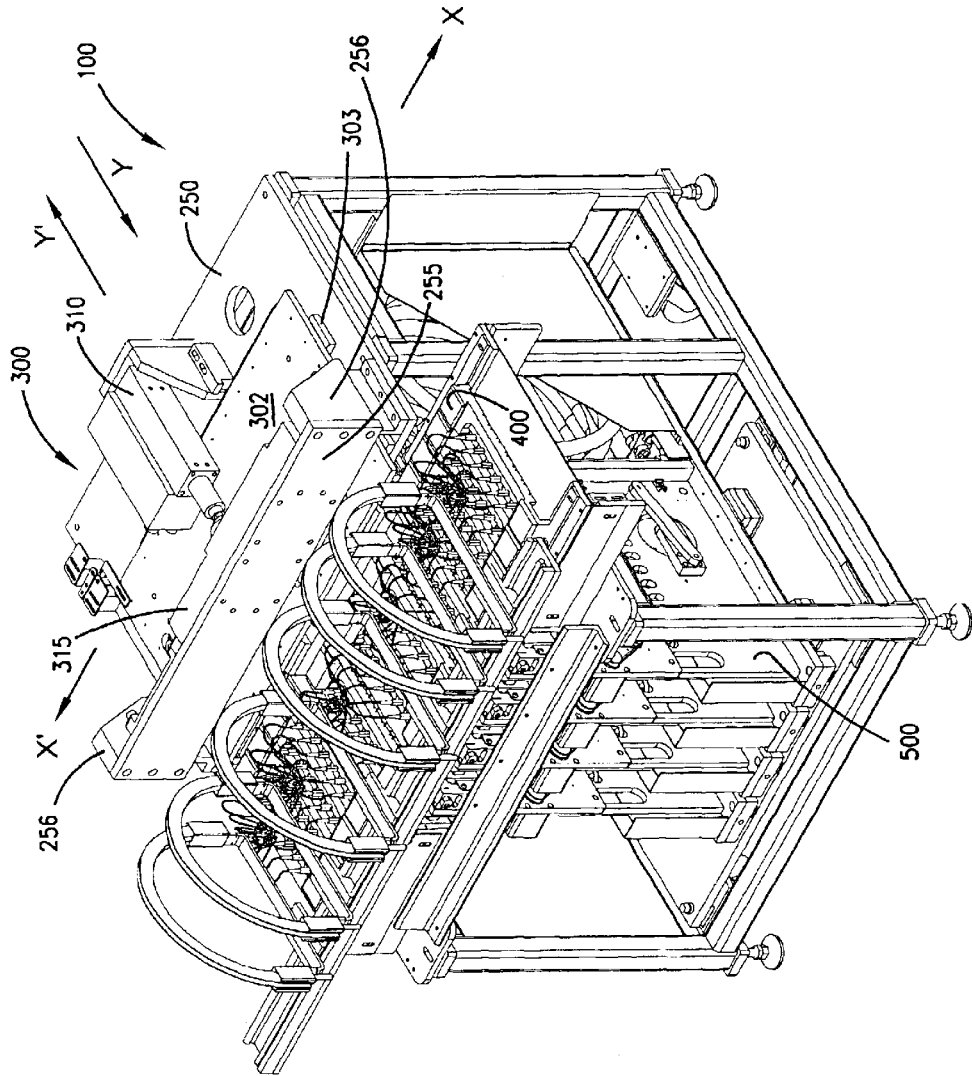
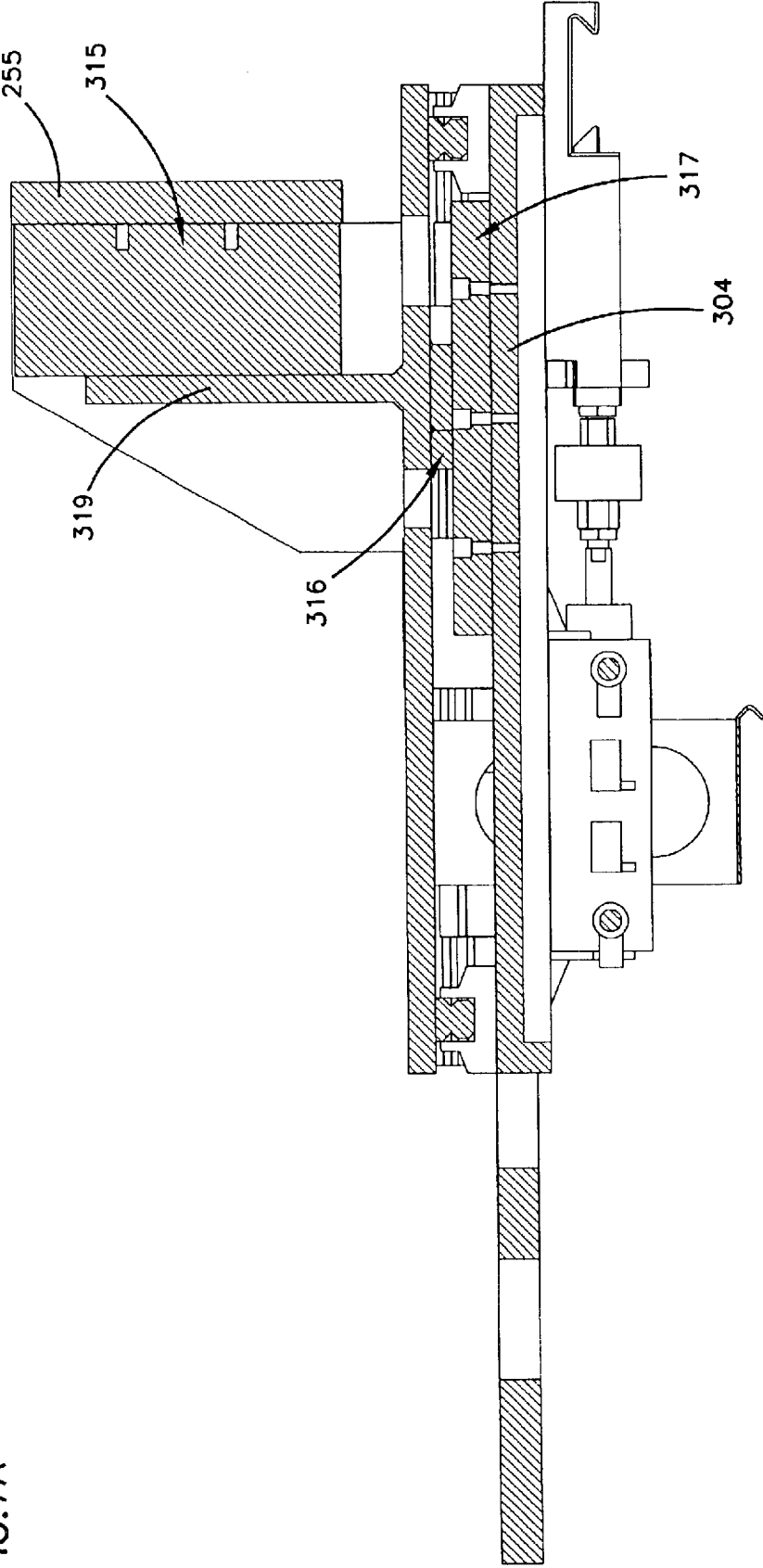

FIG. 7

FIG. 7A



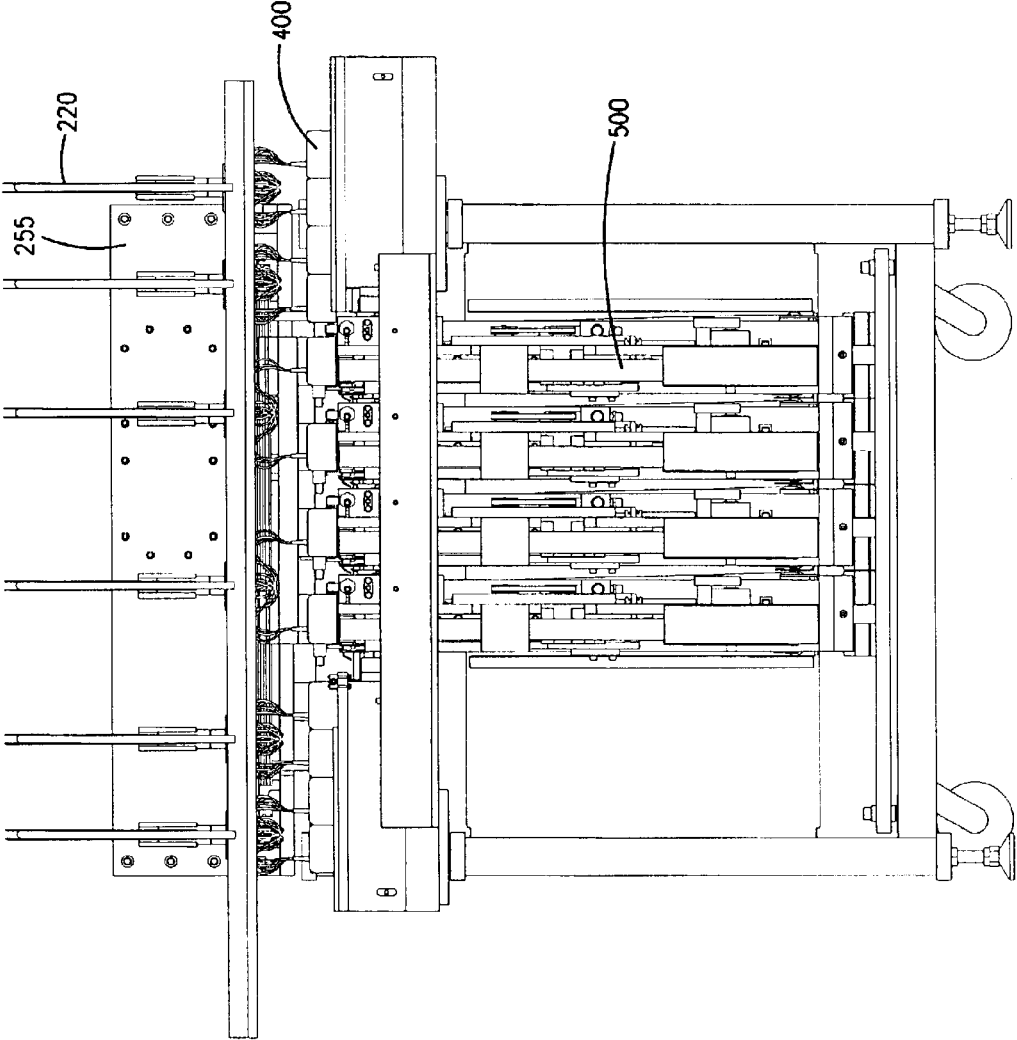

FIG. 8

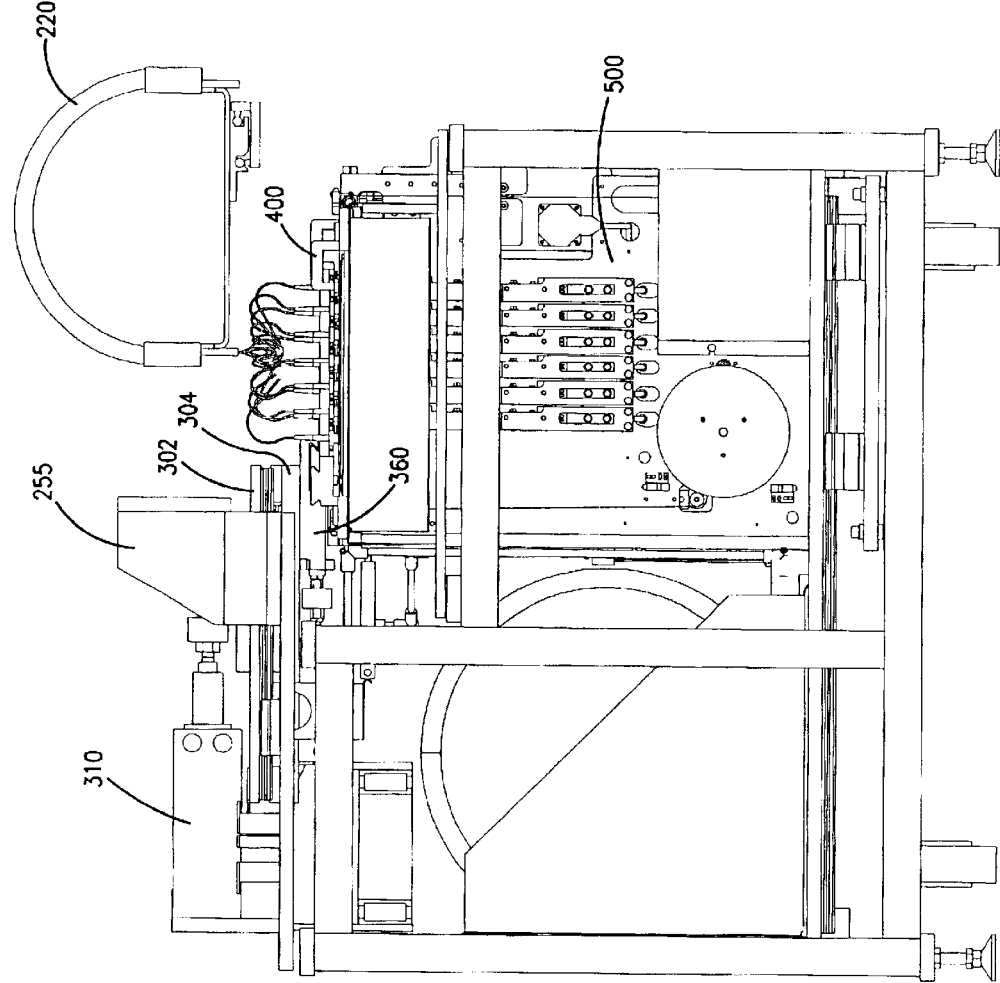

FIG. 9

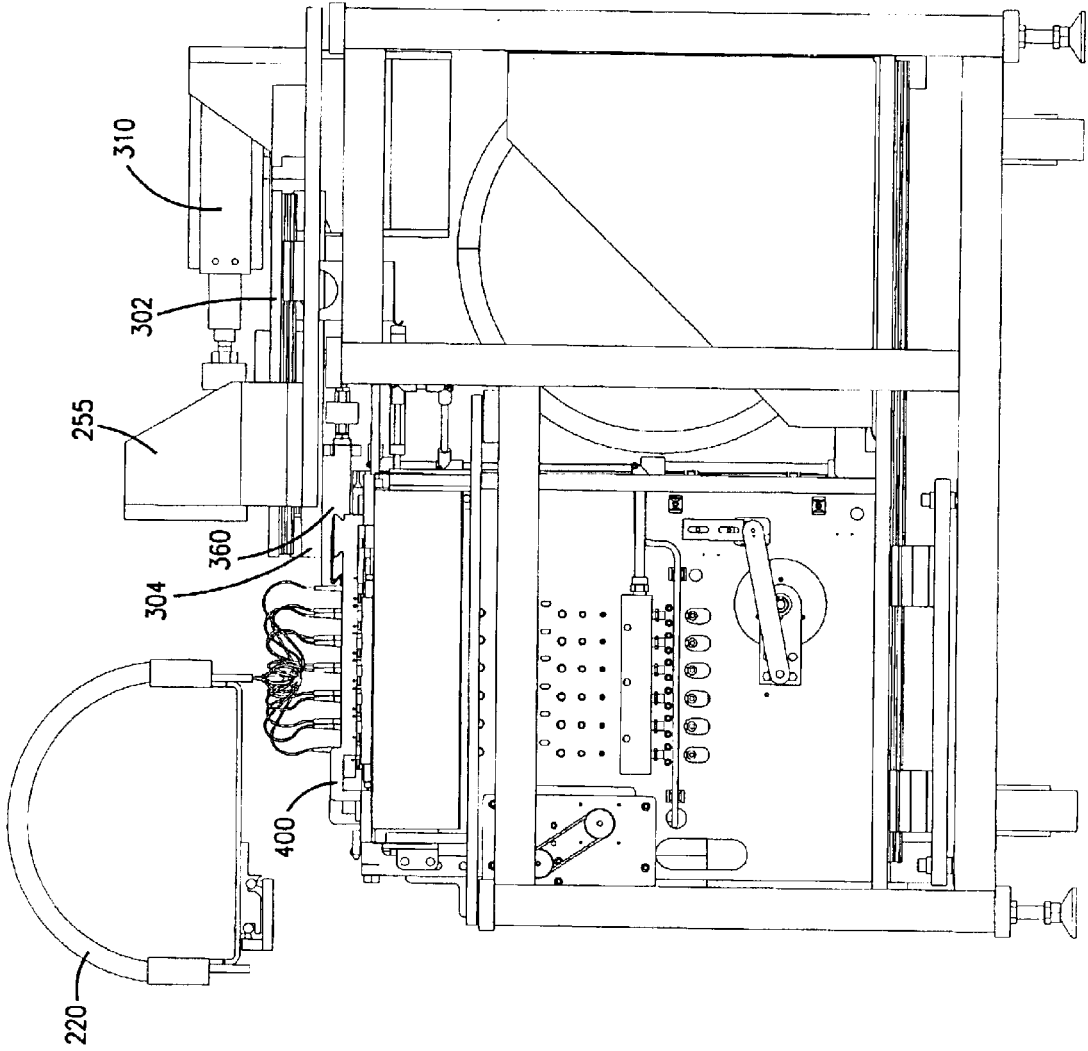

FIG. 10

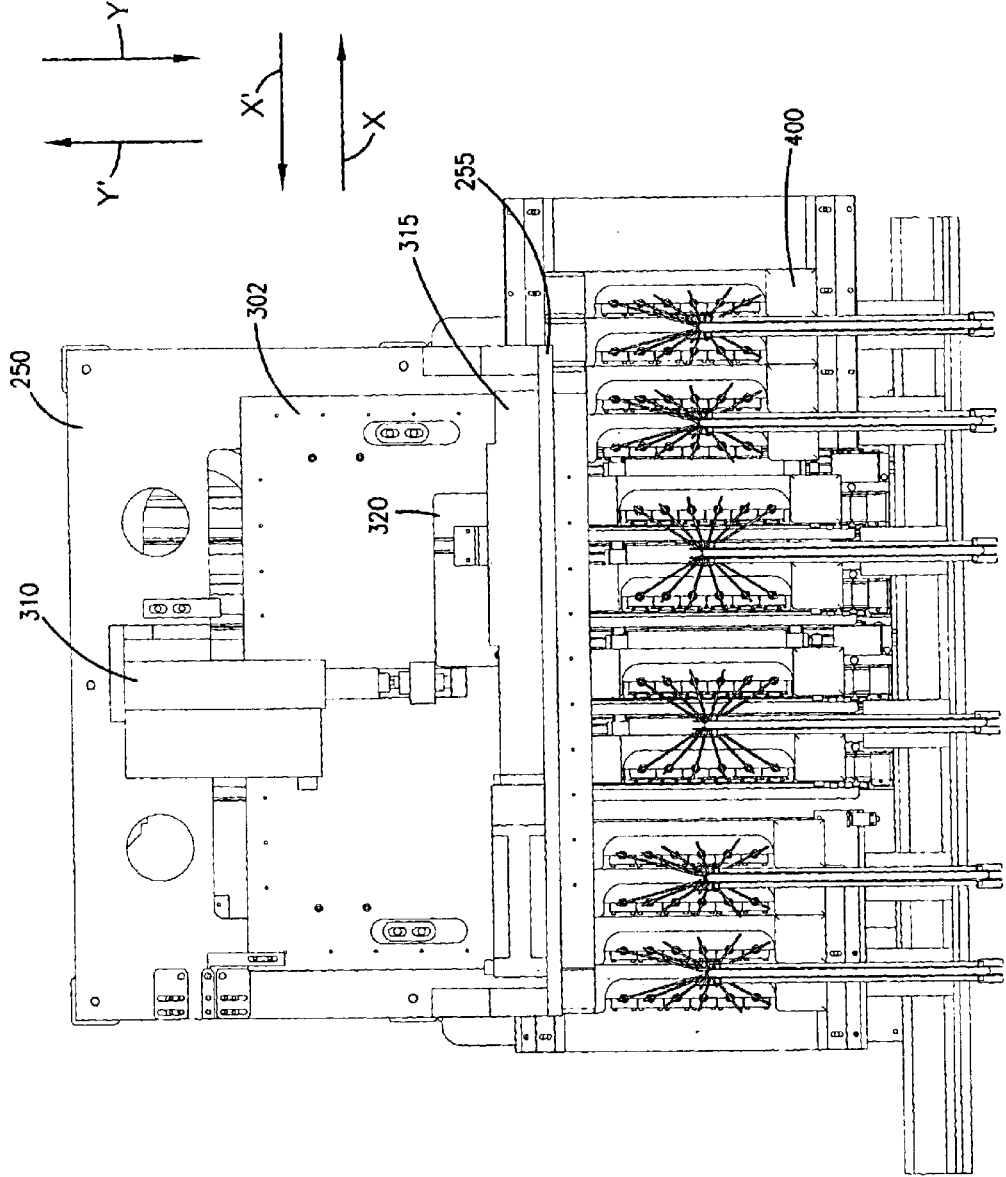
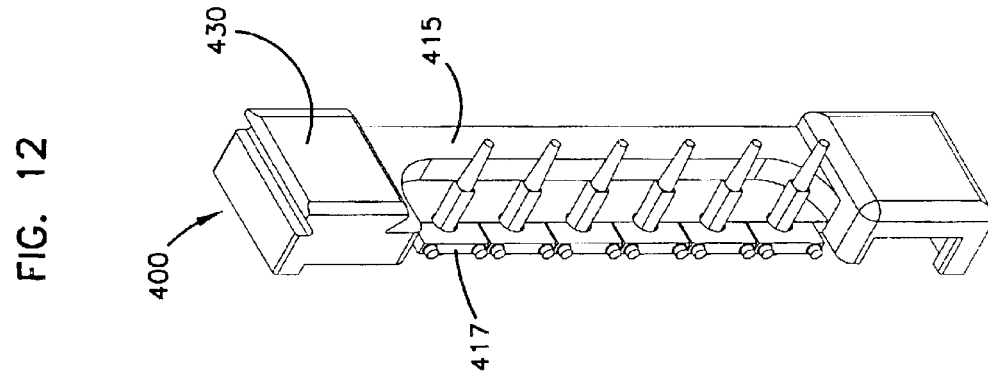
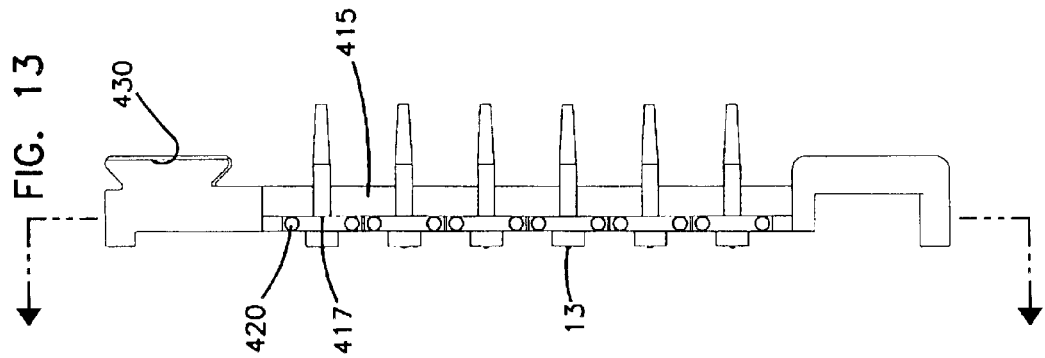
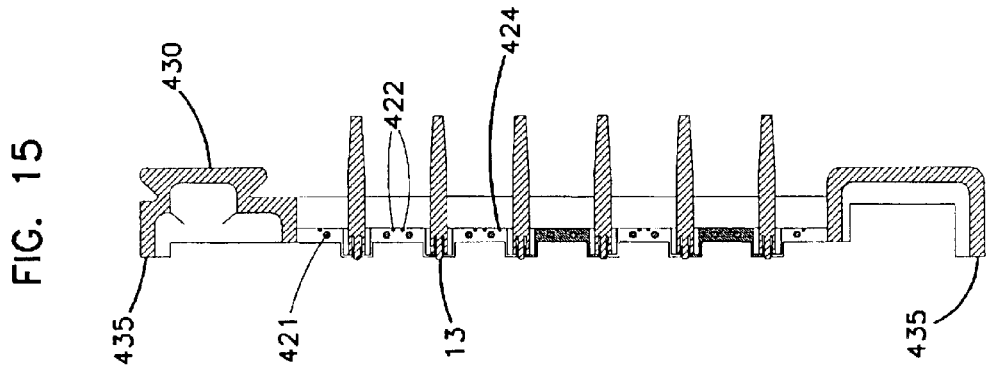
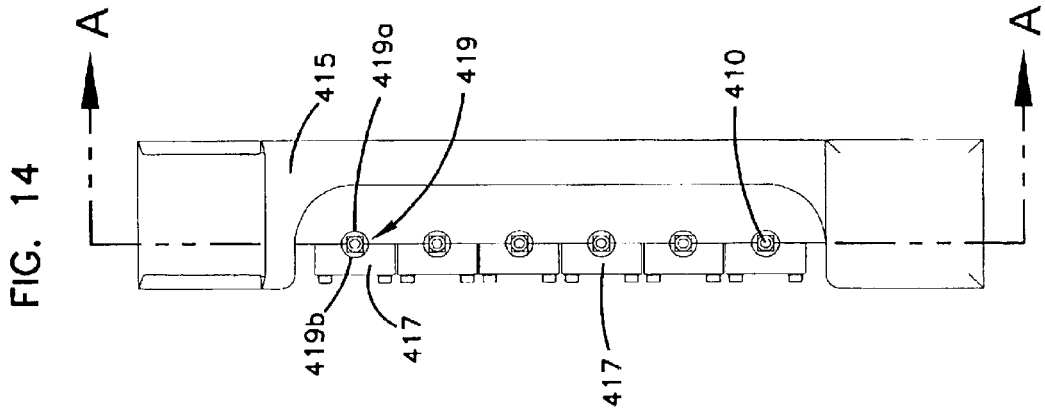

FIG. 11



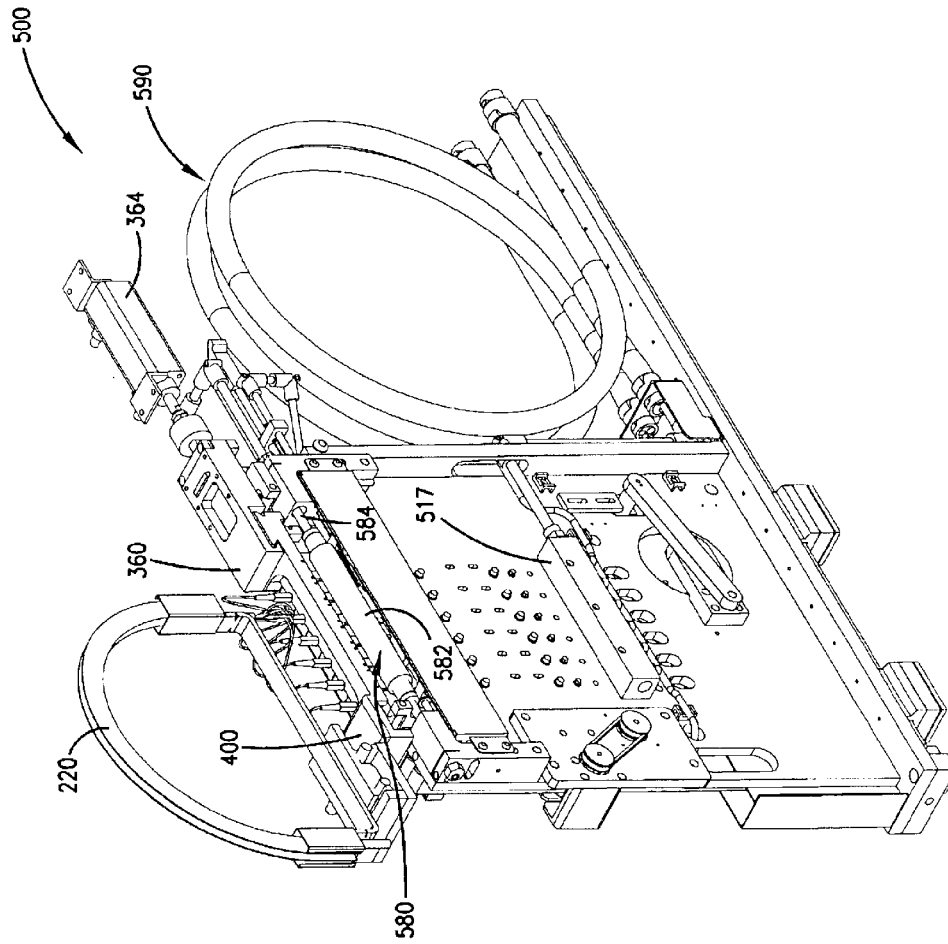

FIG. 16



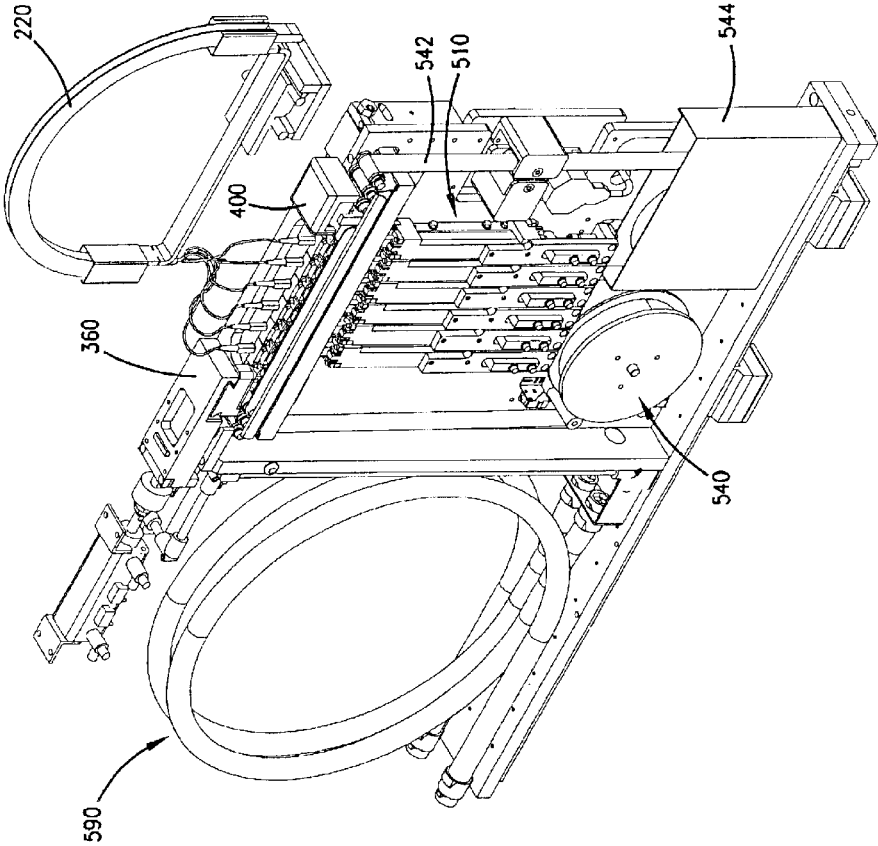
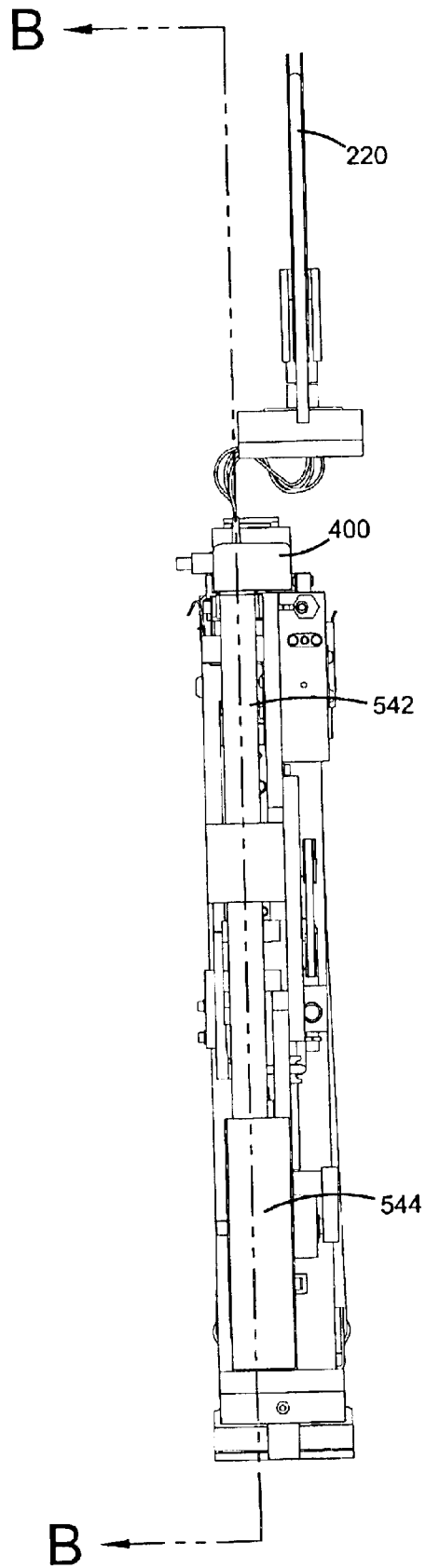

FIG. 17

FIG. 18



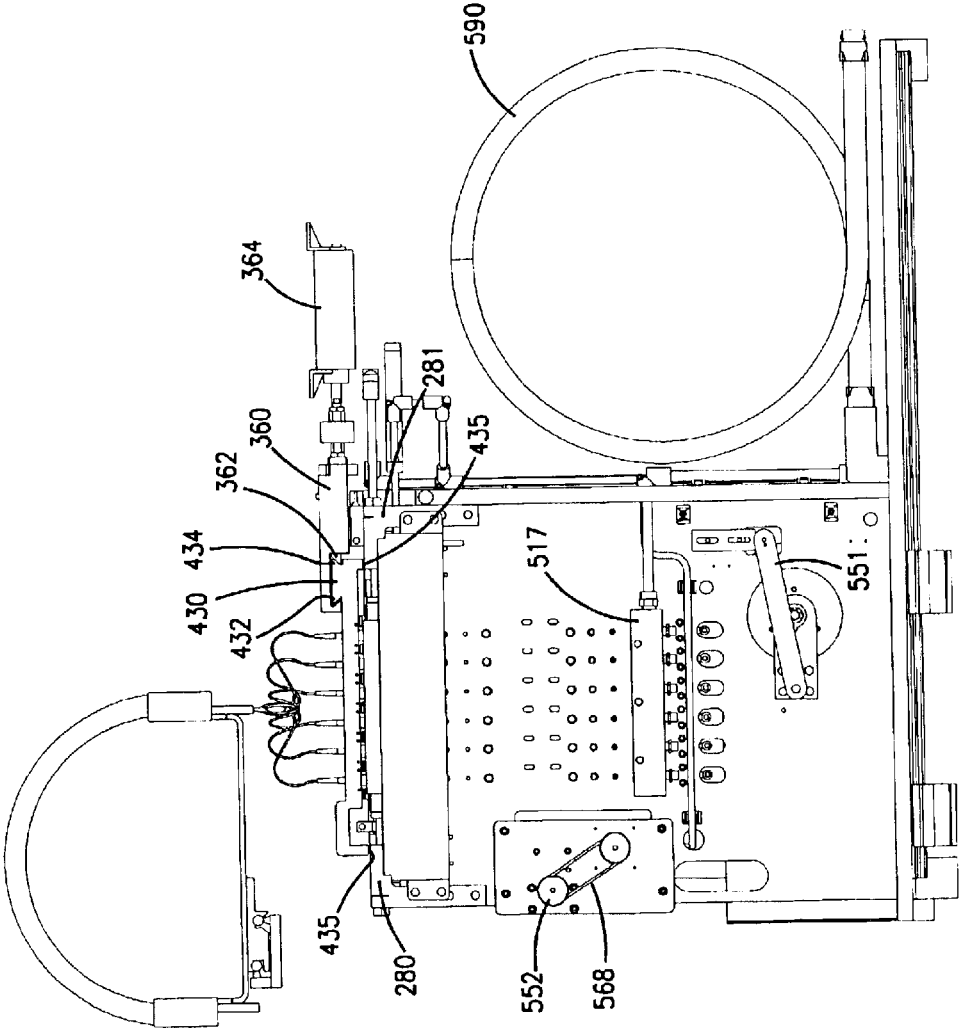

FIG. 19

FIG. 20

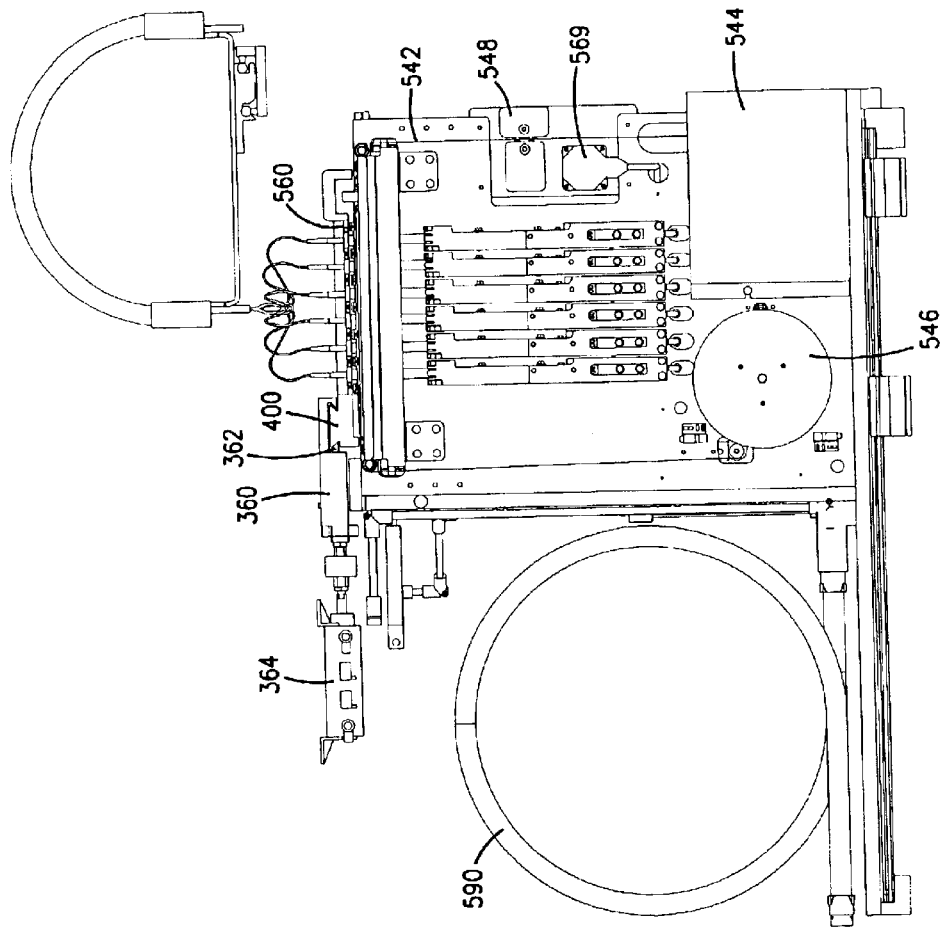
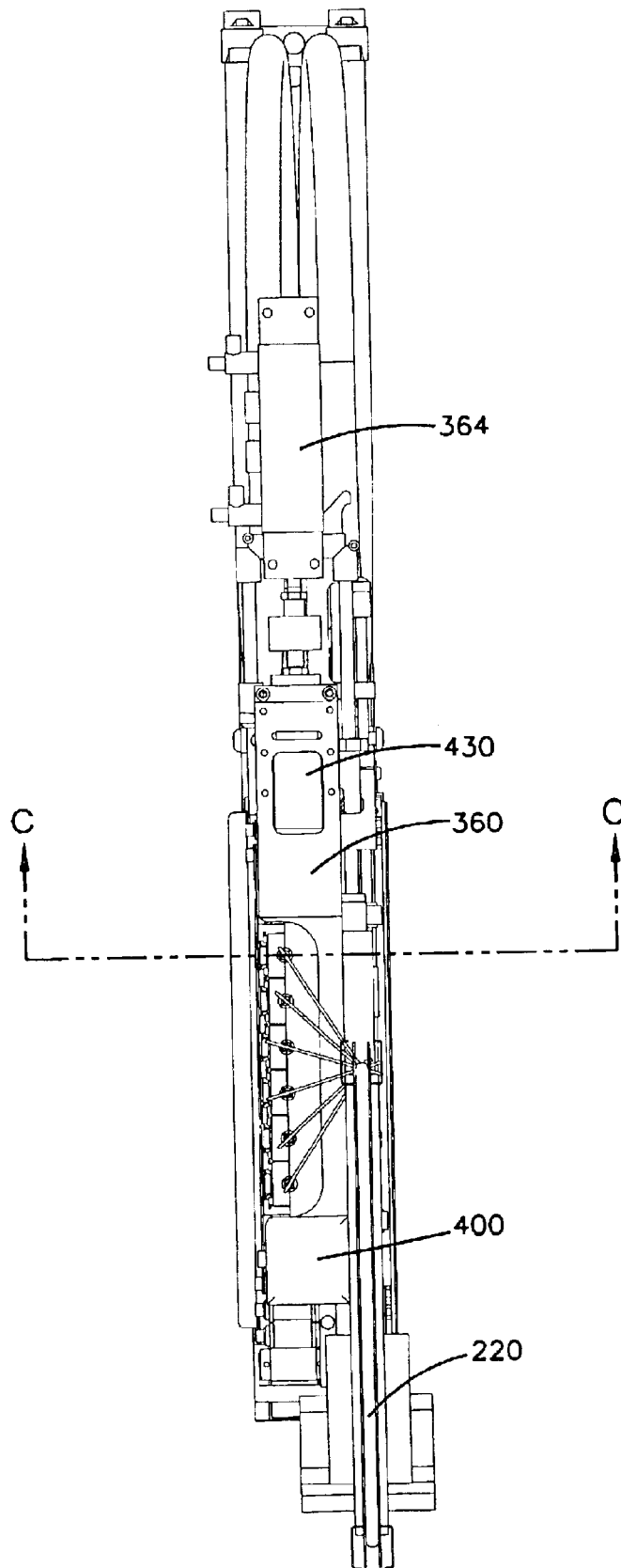

FIG. 21



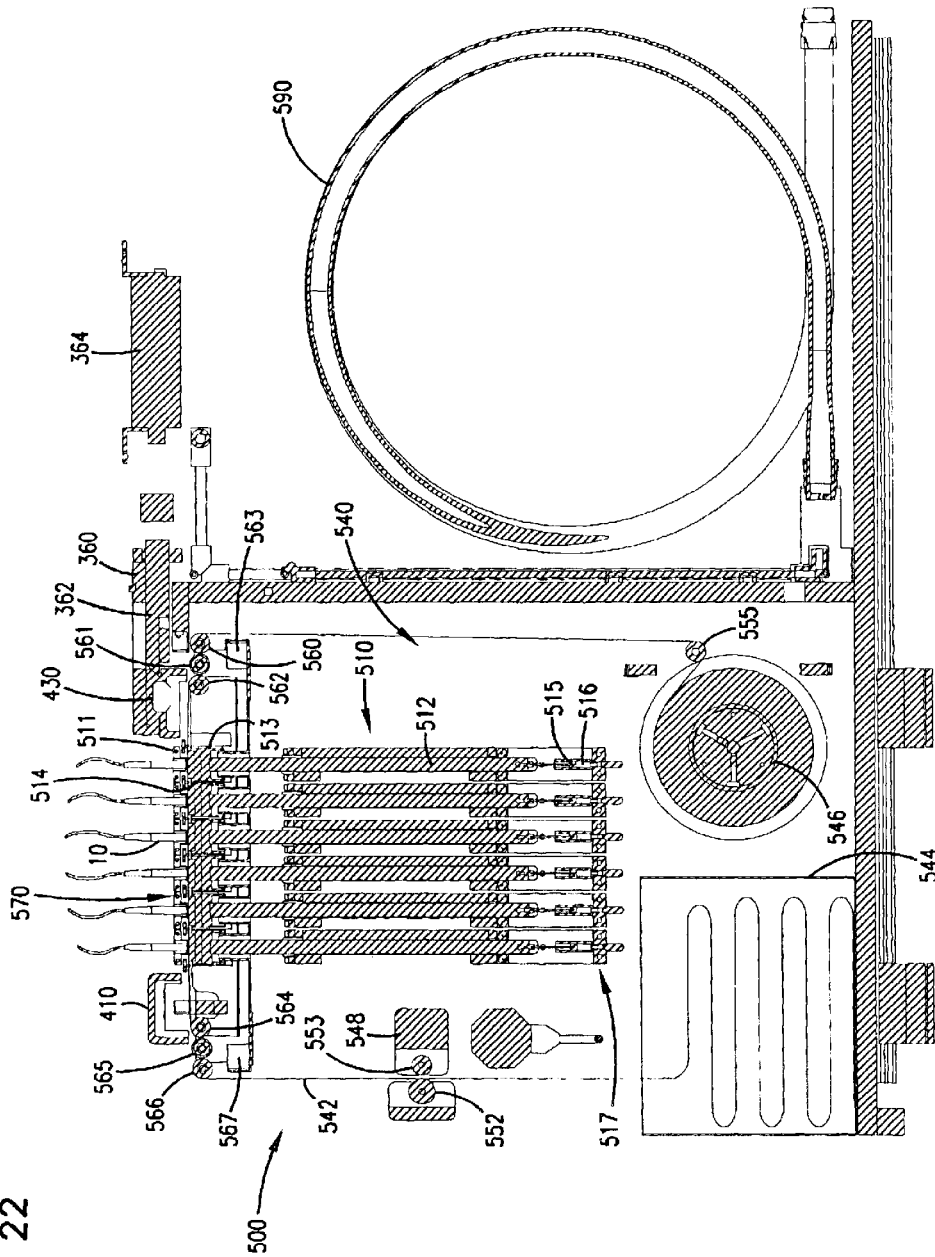

FIG. 22

FIG. 23

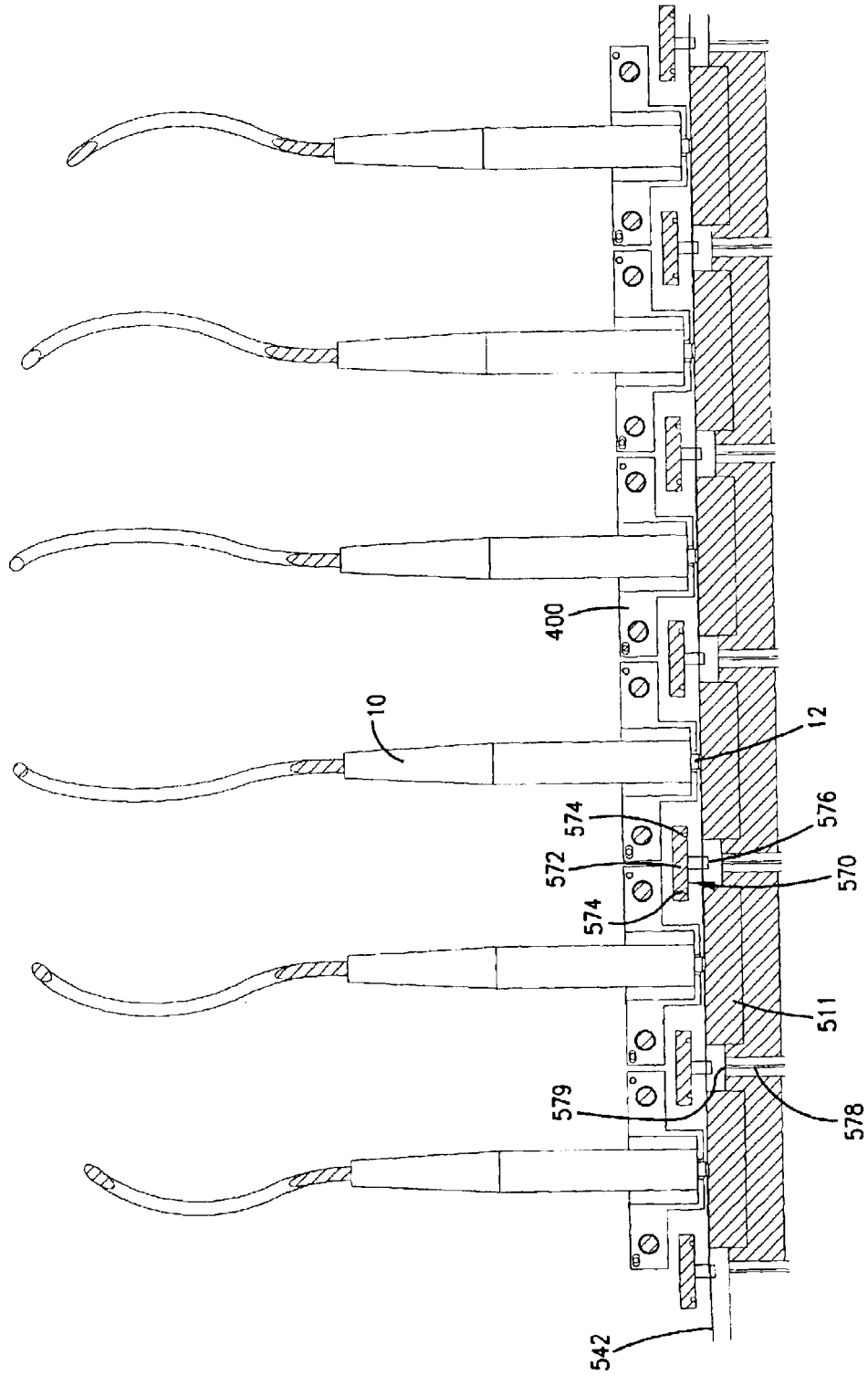

FIG. 24

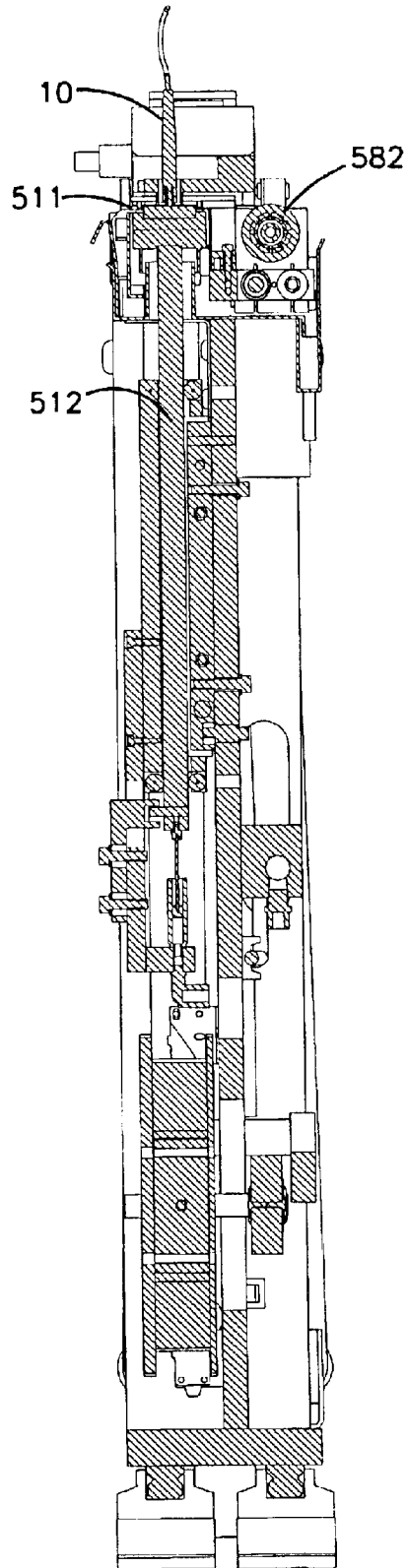
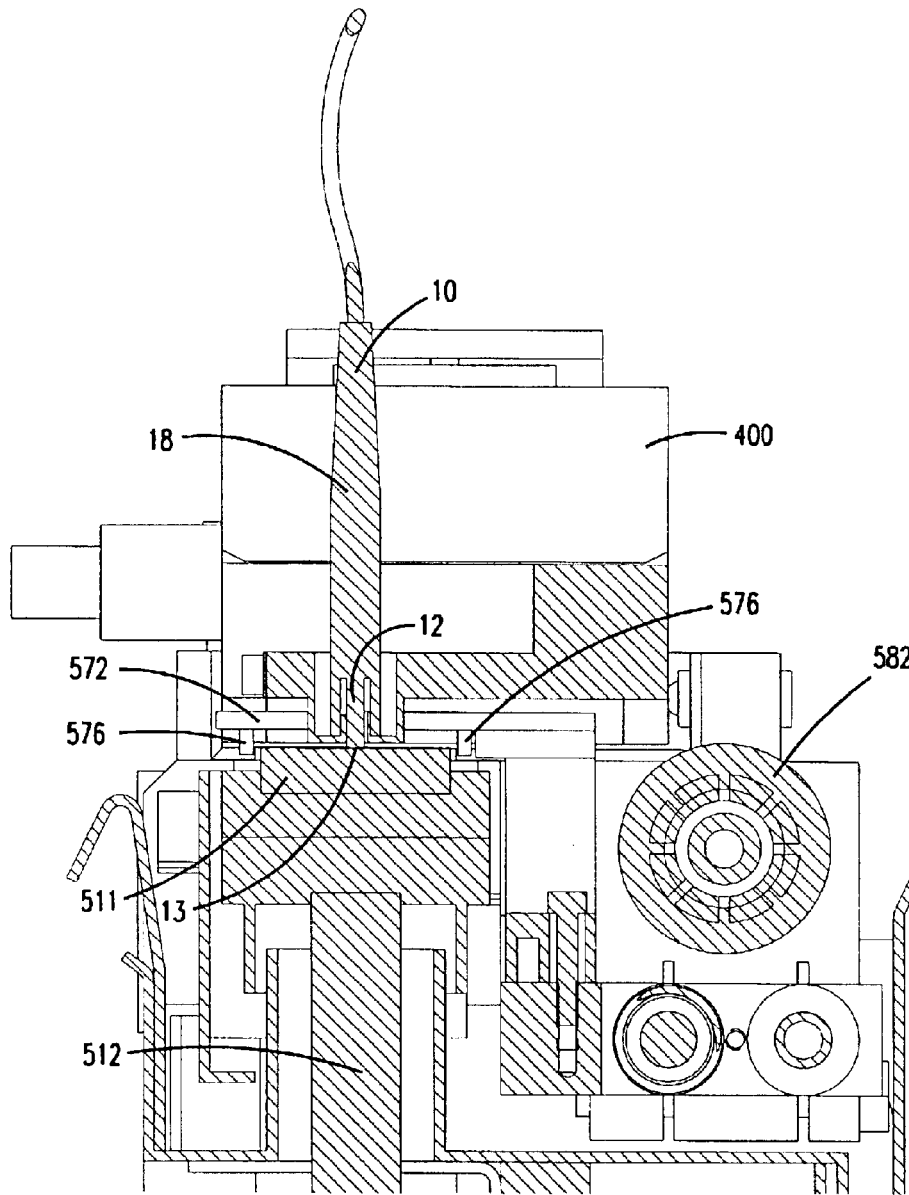
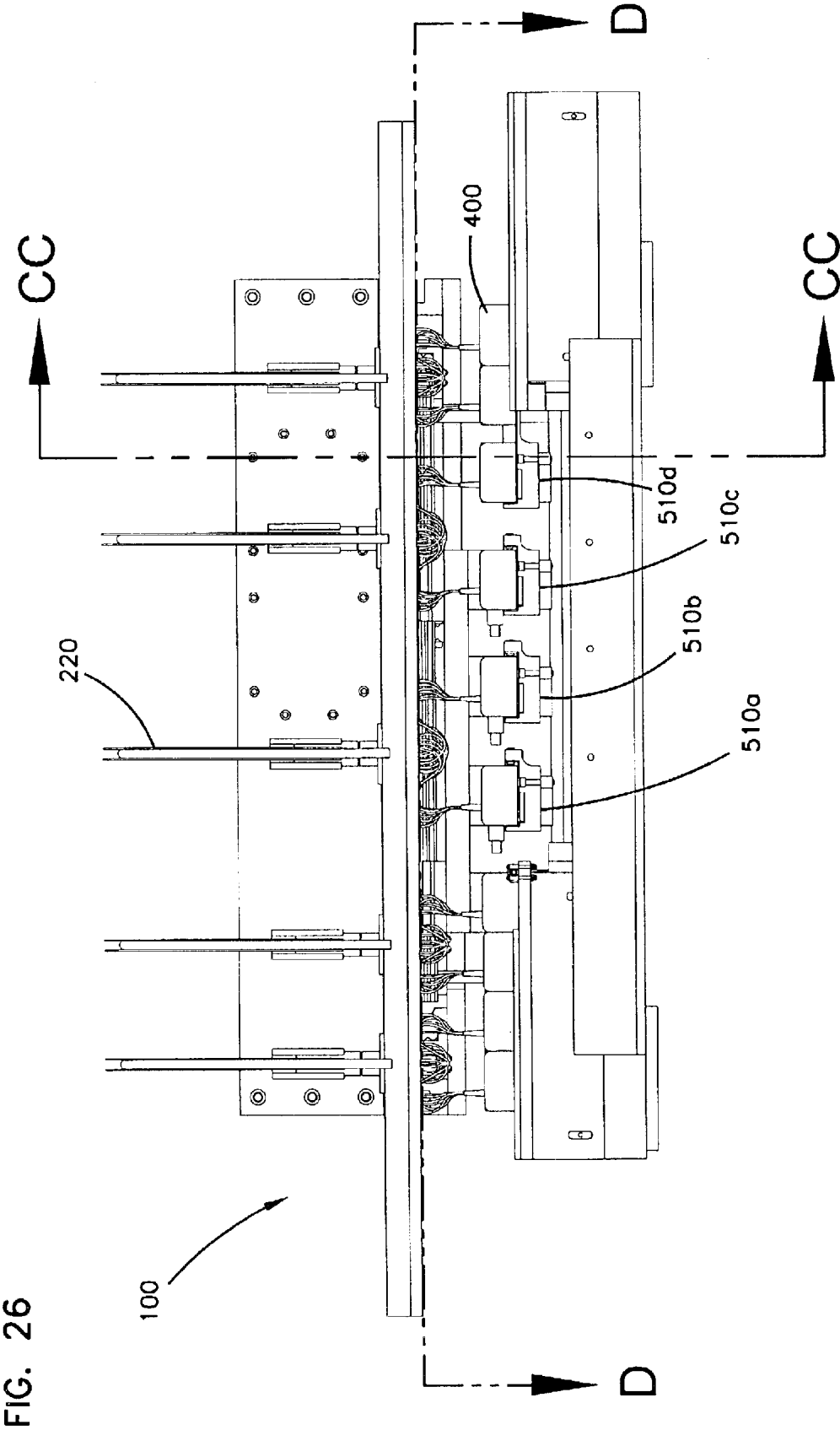



FIG. 25





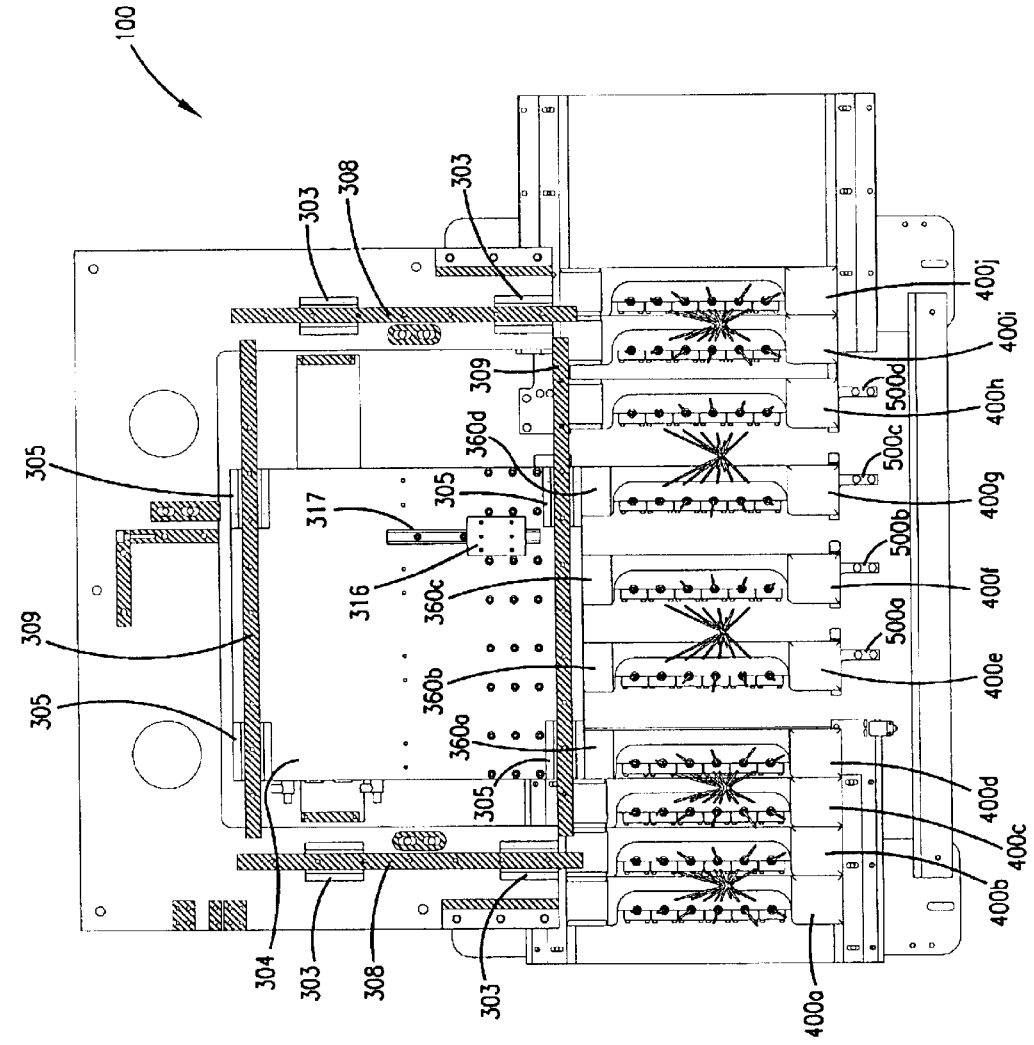

FIG. 27

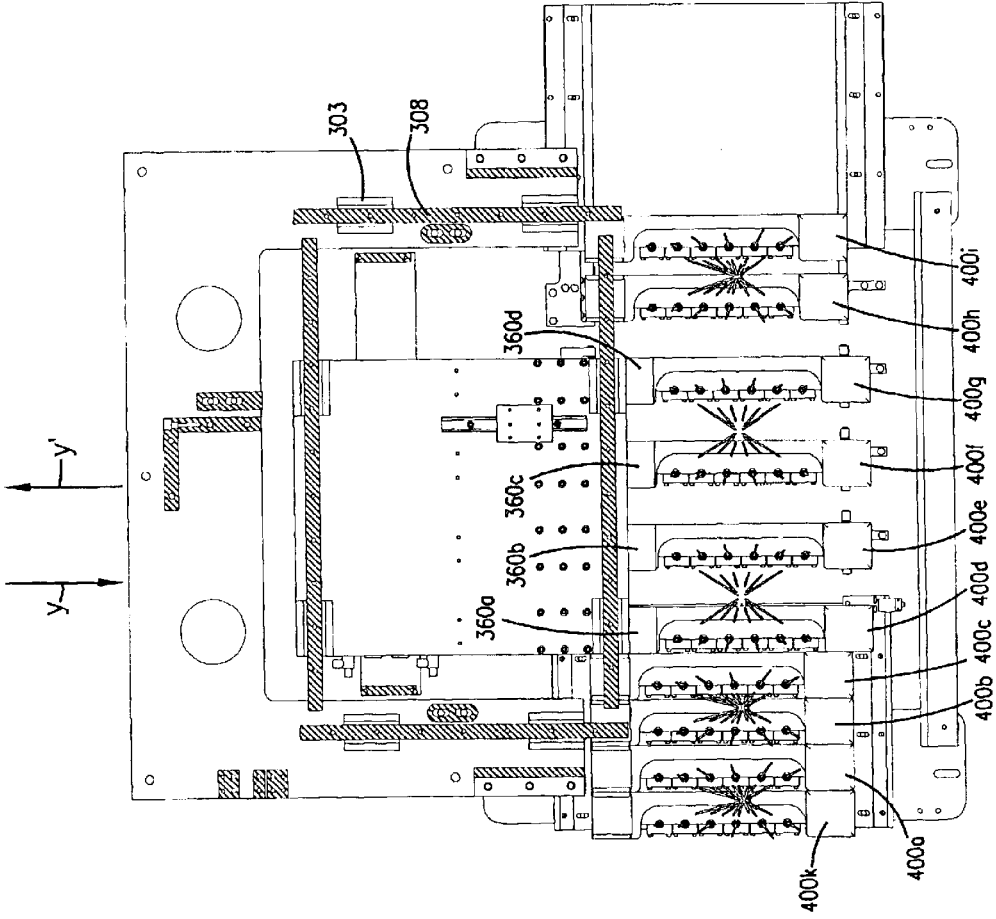
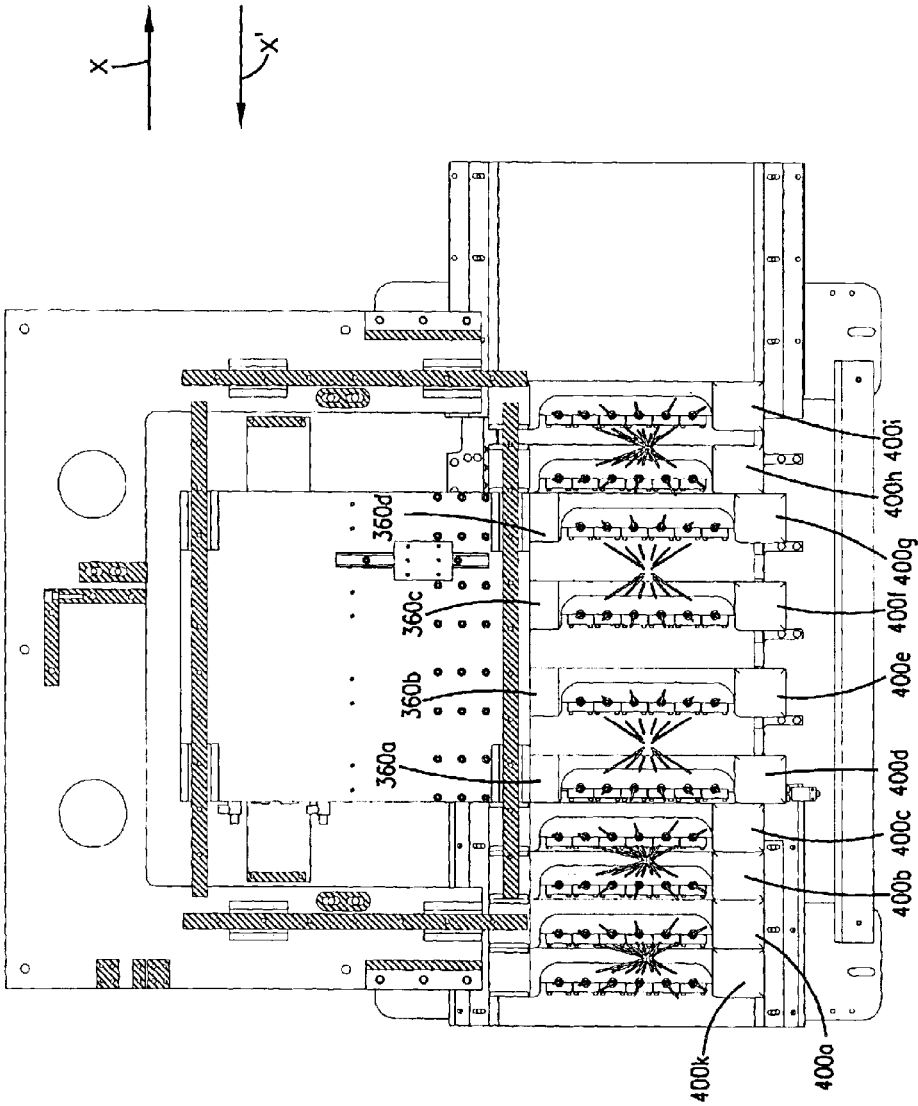

FIG. 28

FIG. 29



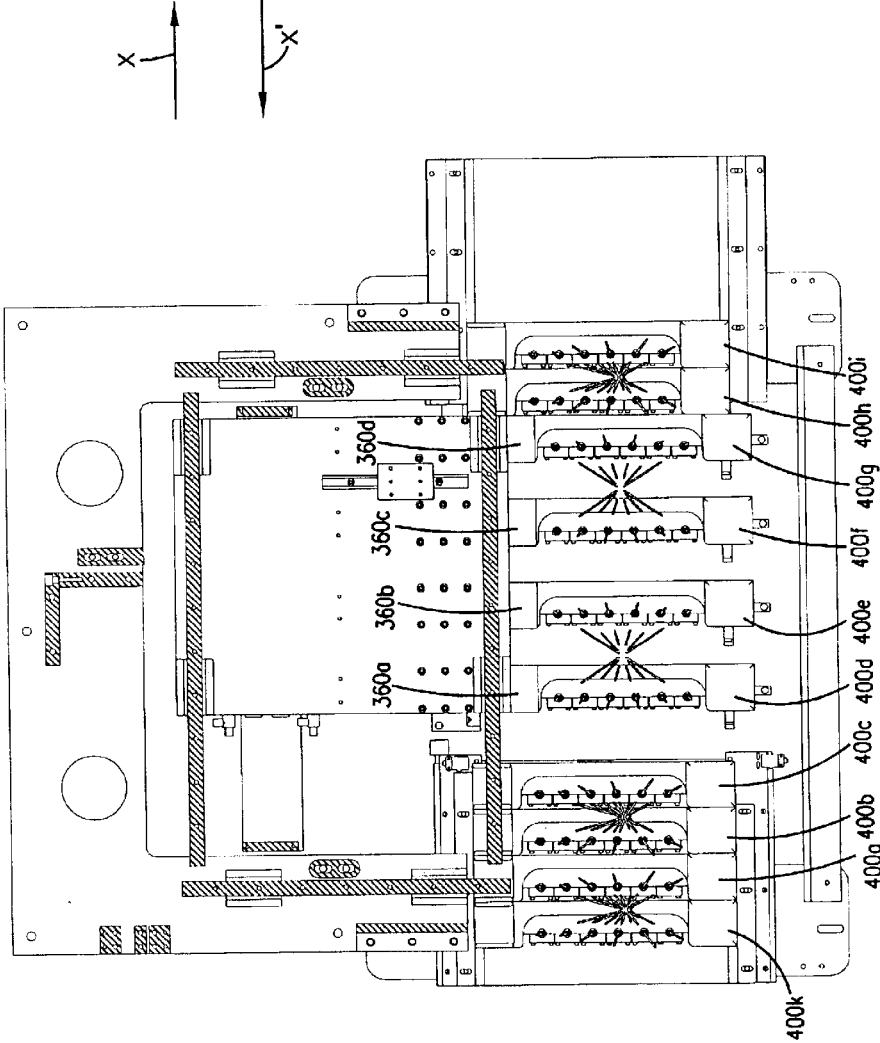

FIG. 30

FIG. 31

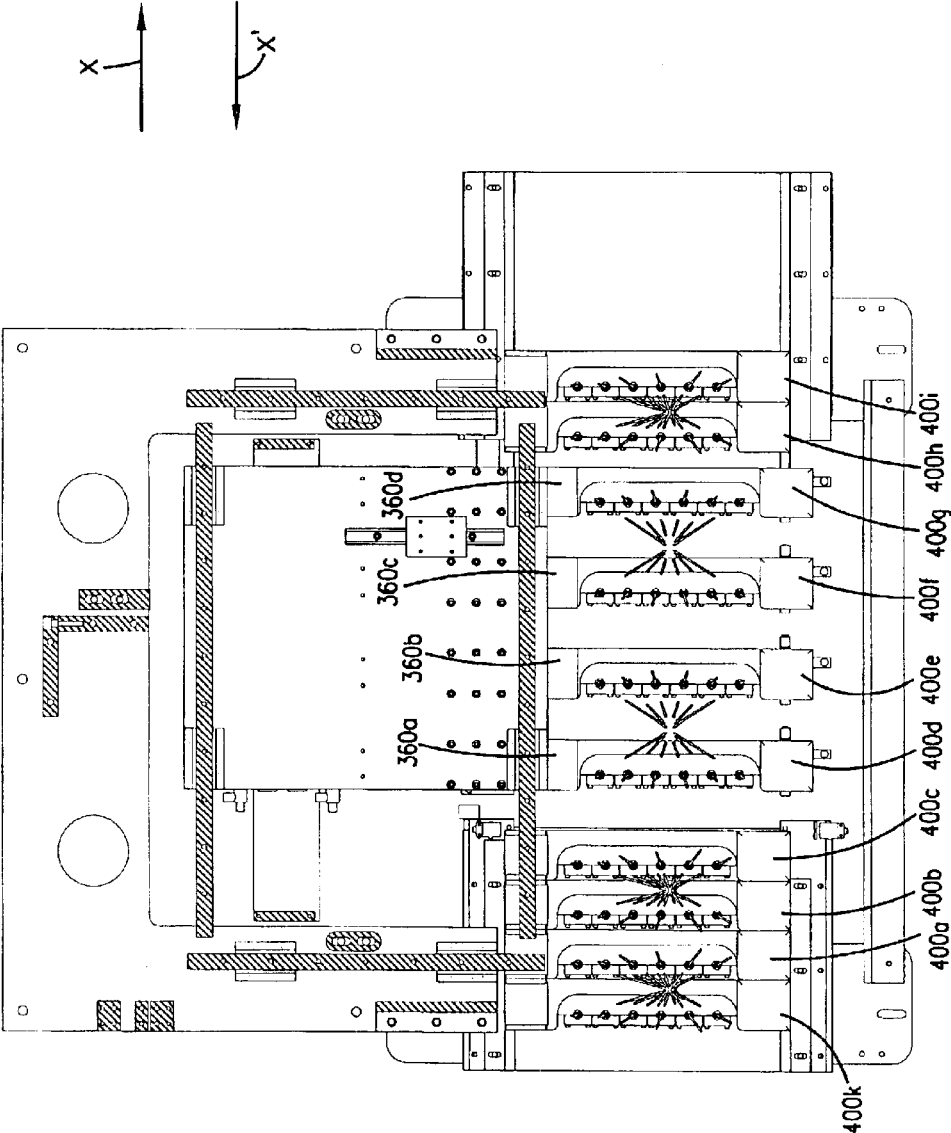

FIG.31A

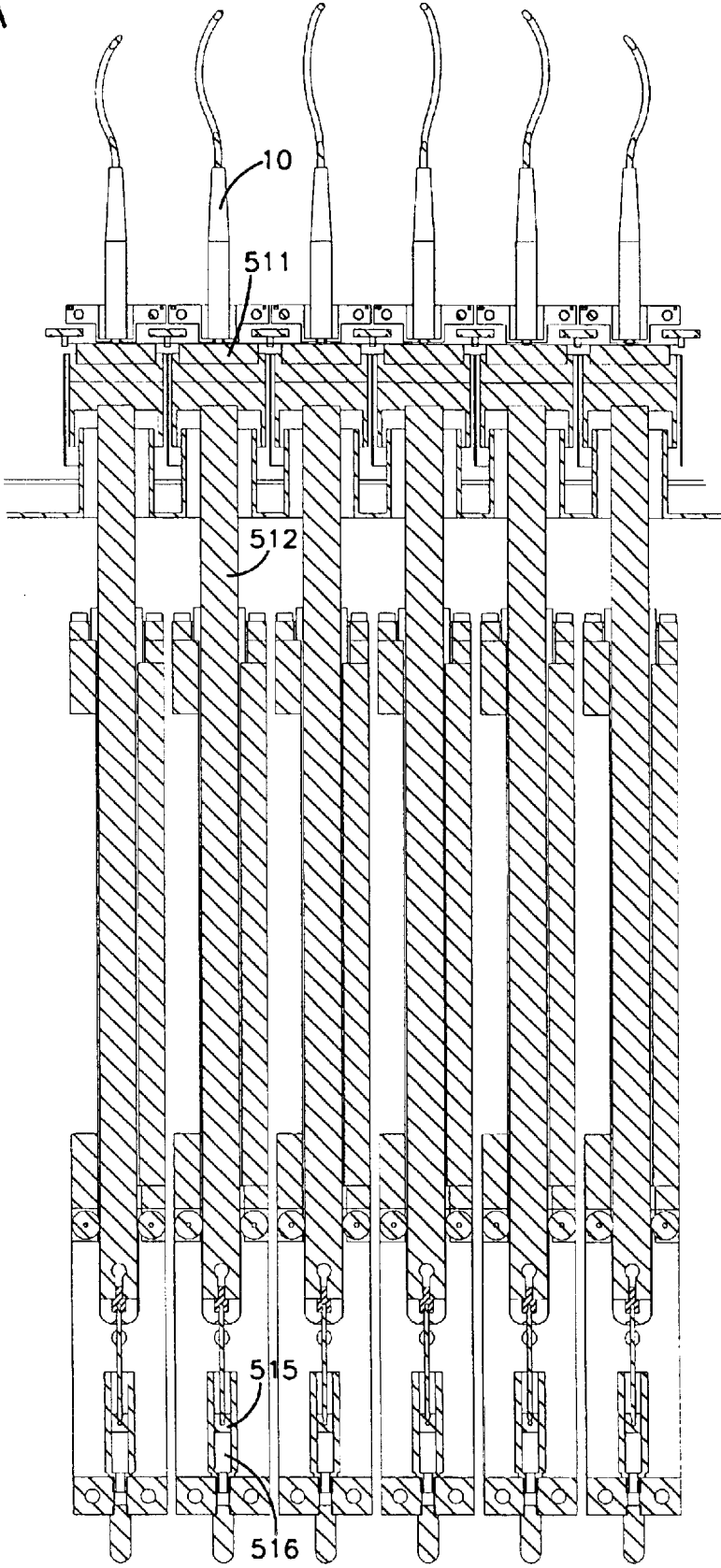
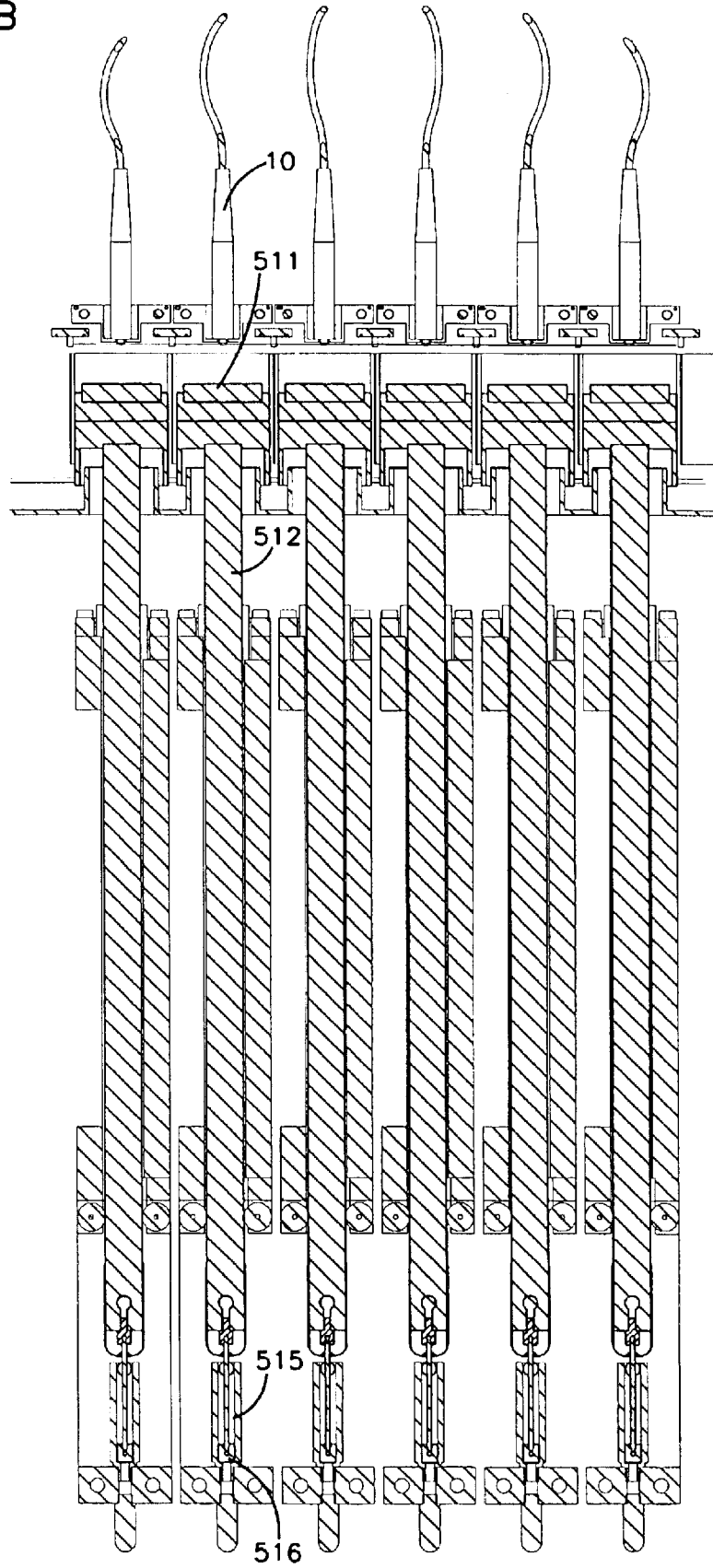



FIG.31B



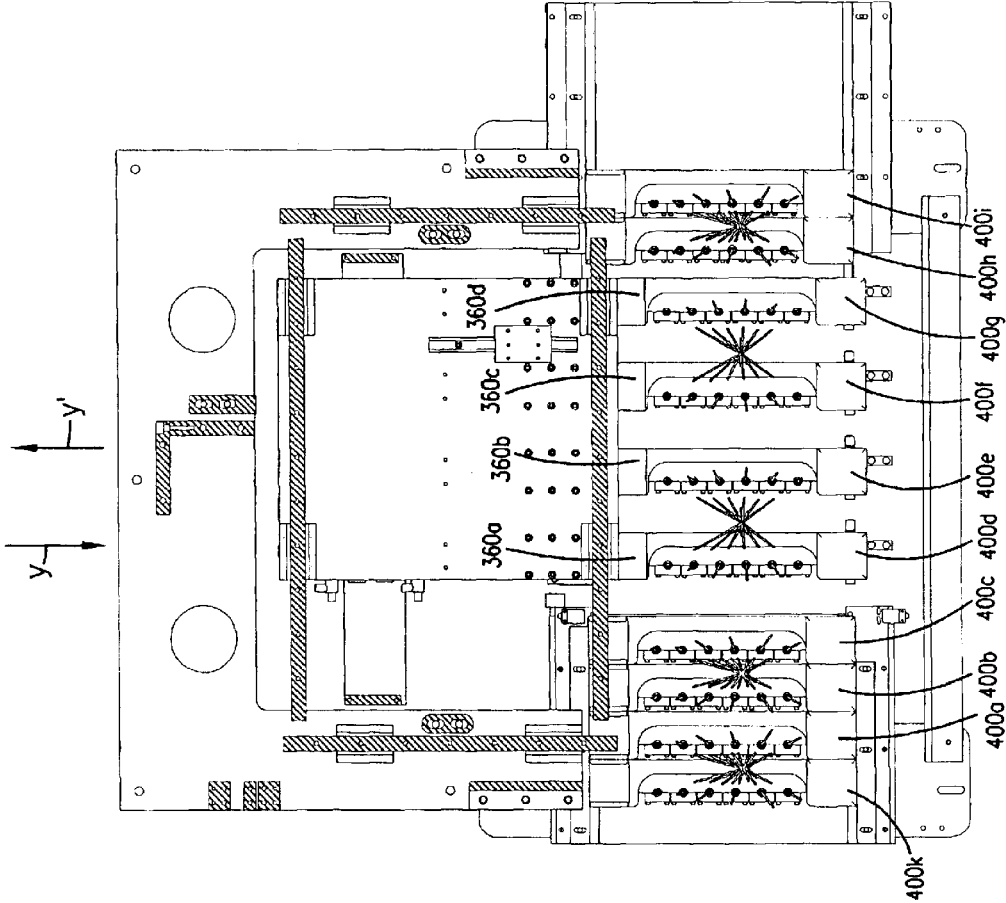

FIG. 32

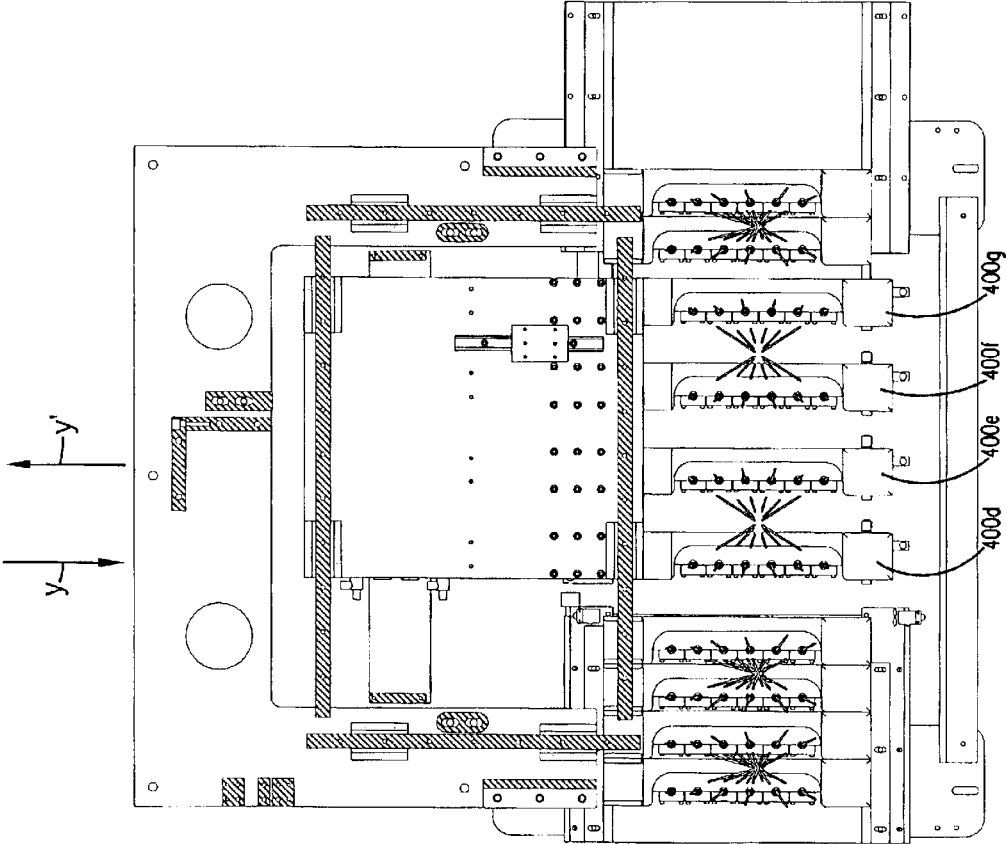

FIG. 33

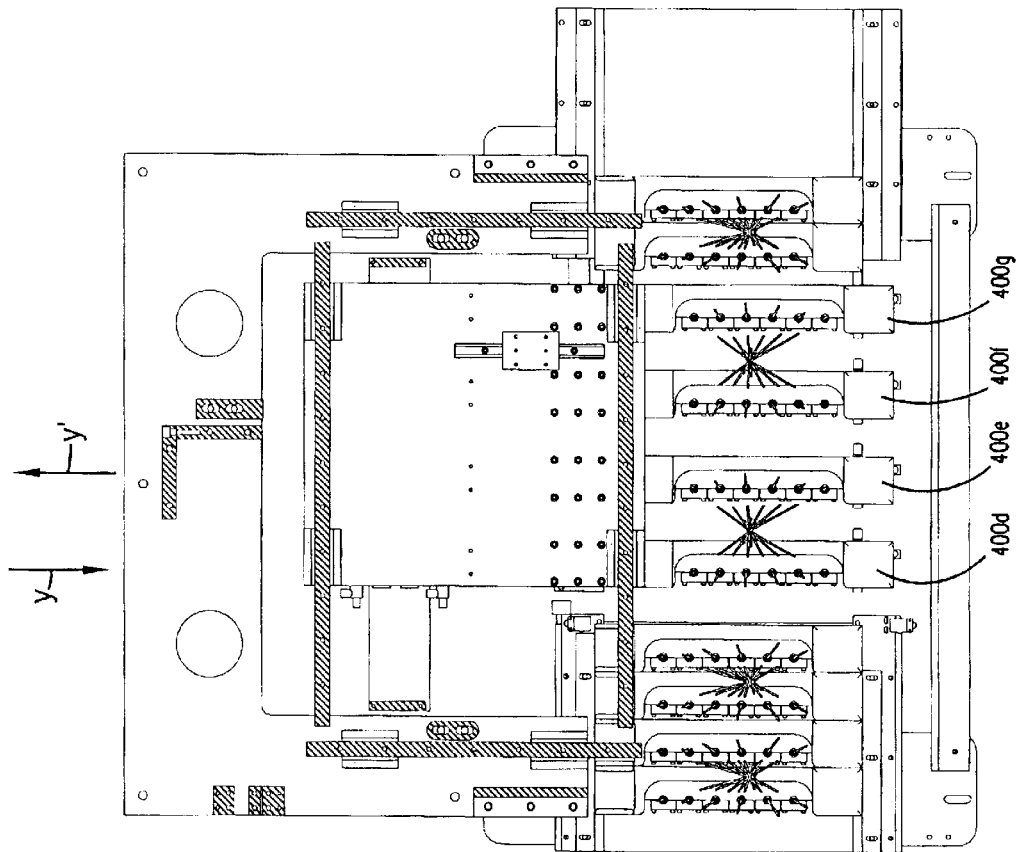

FIG. 34

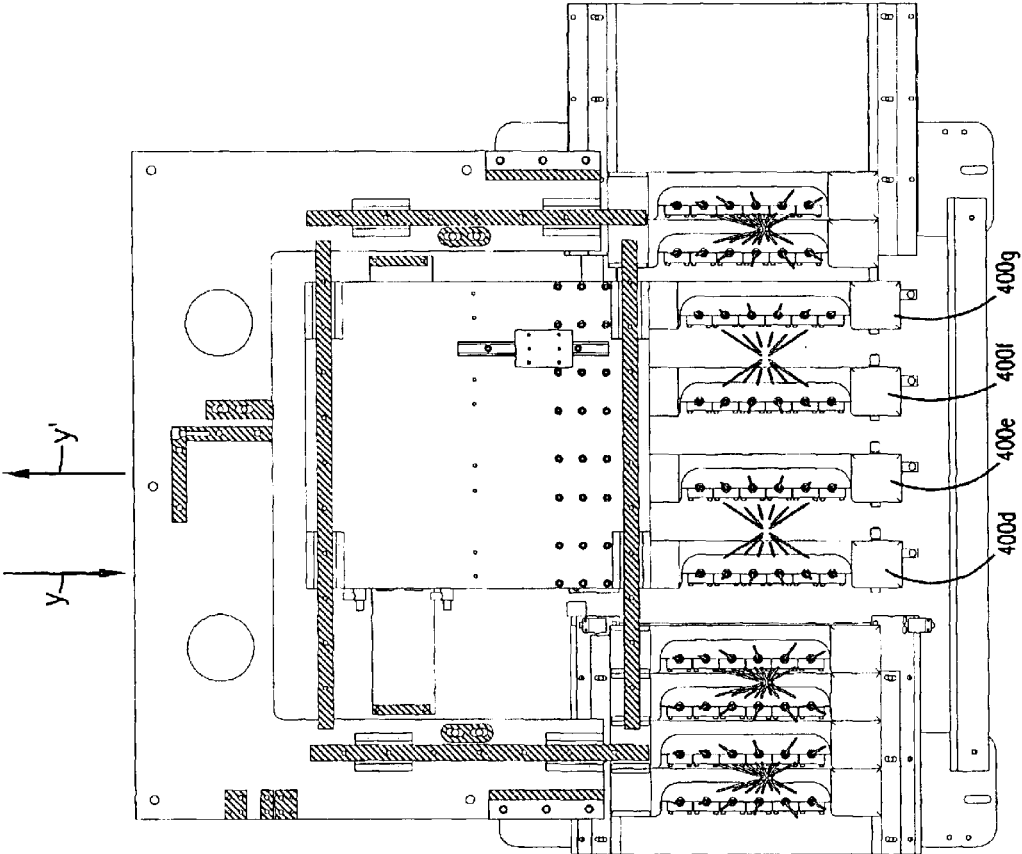

FIG. 35

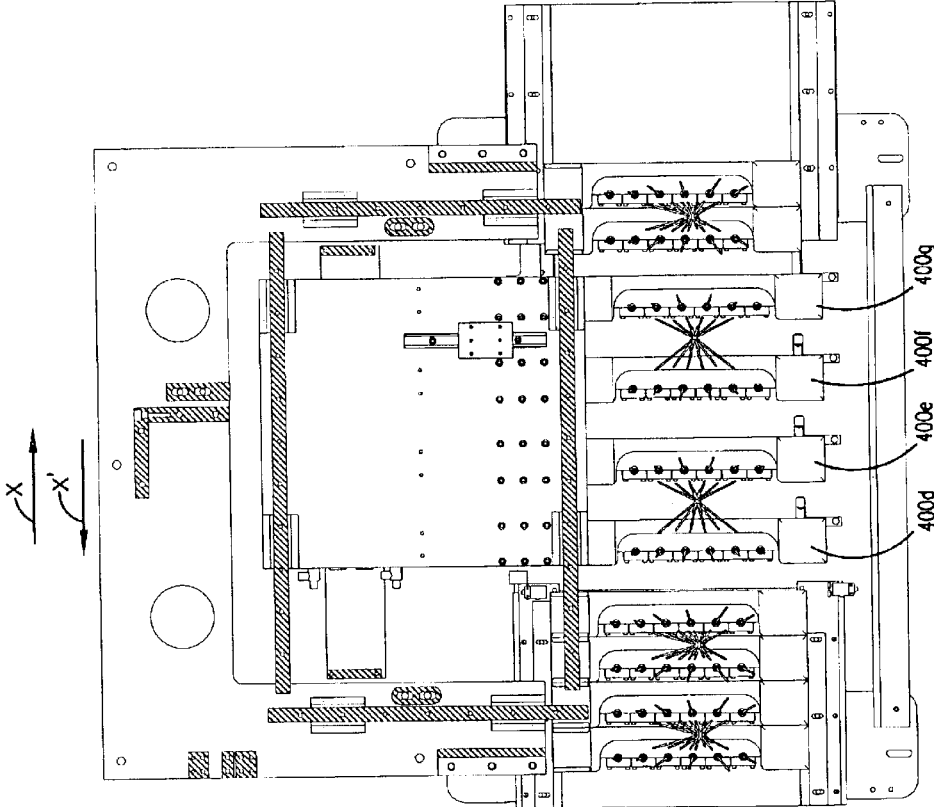

FIG. 36

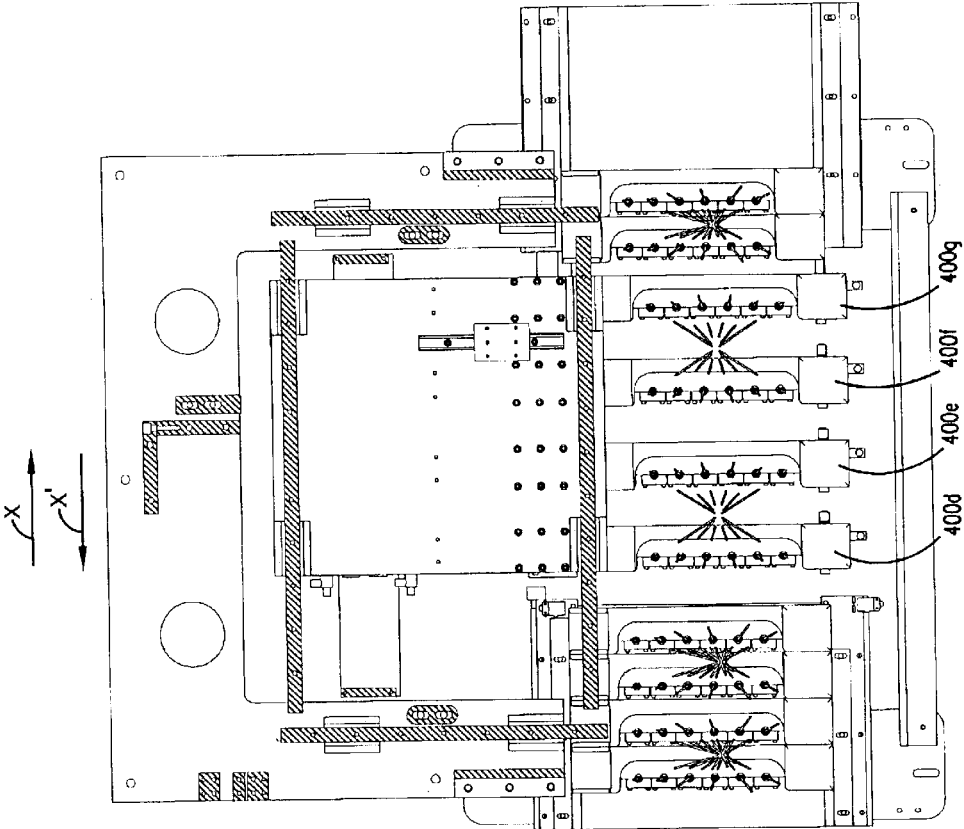

FIG. 37

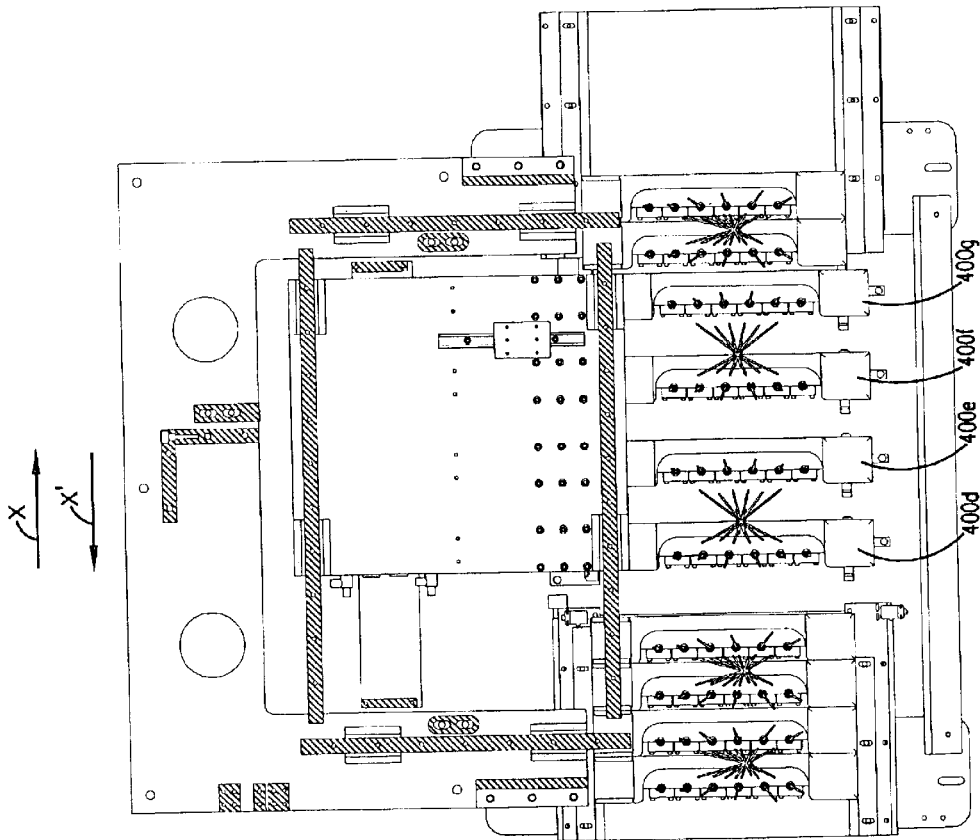

FIG. 38



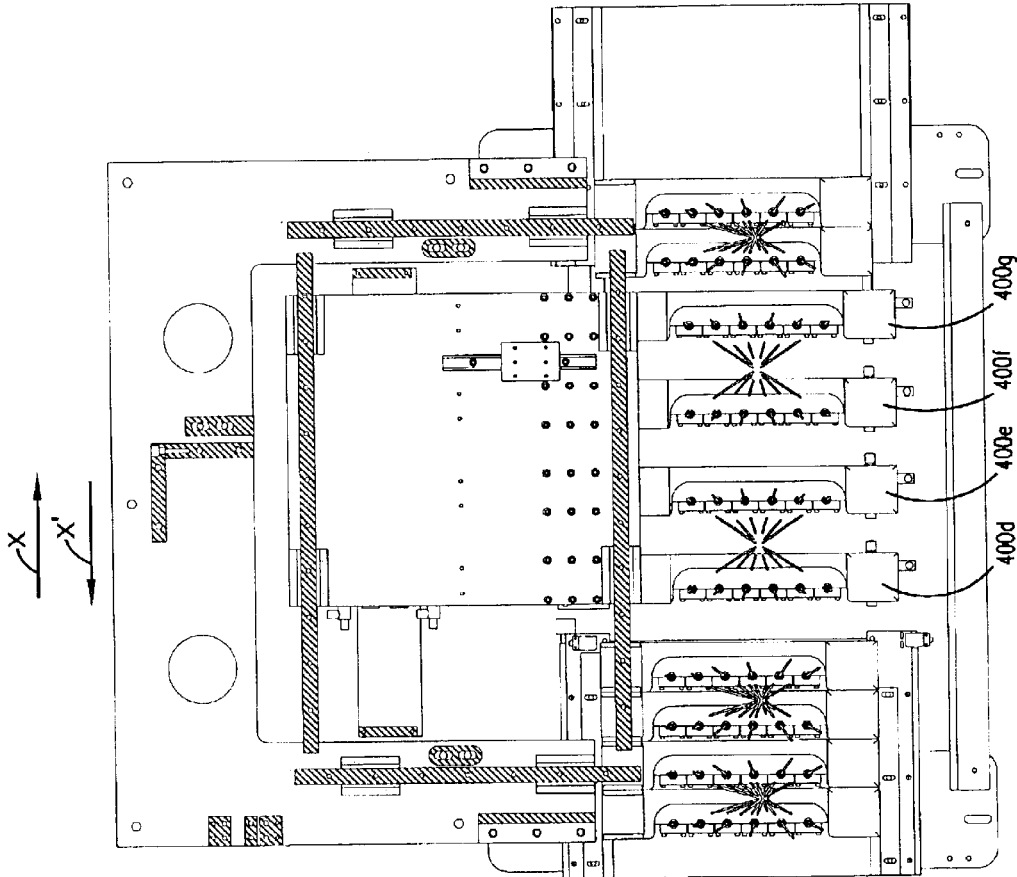

FIG. 39

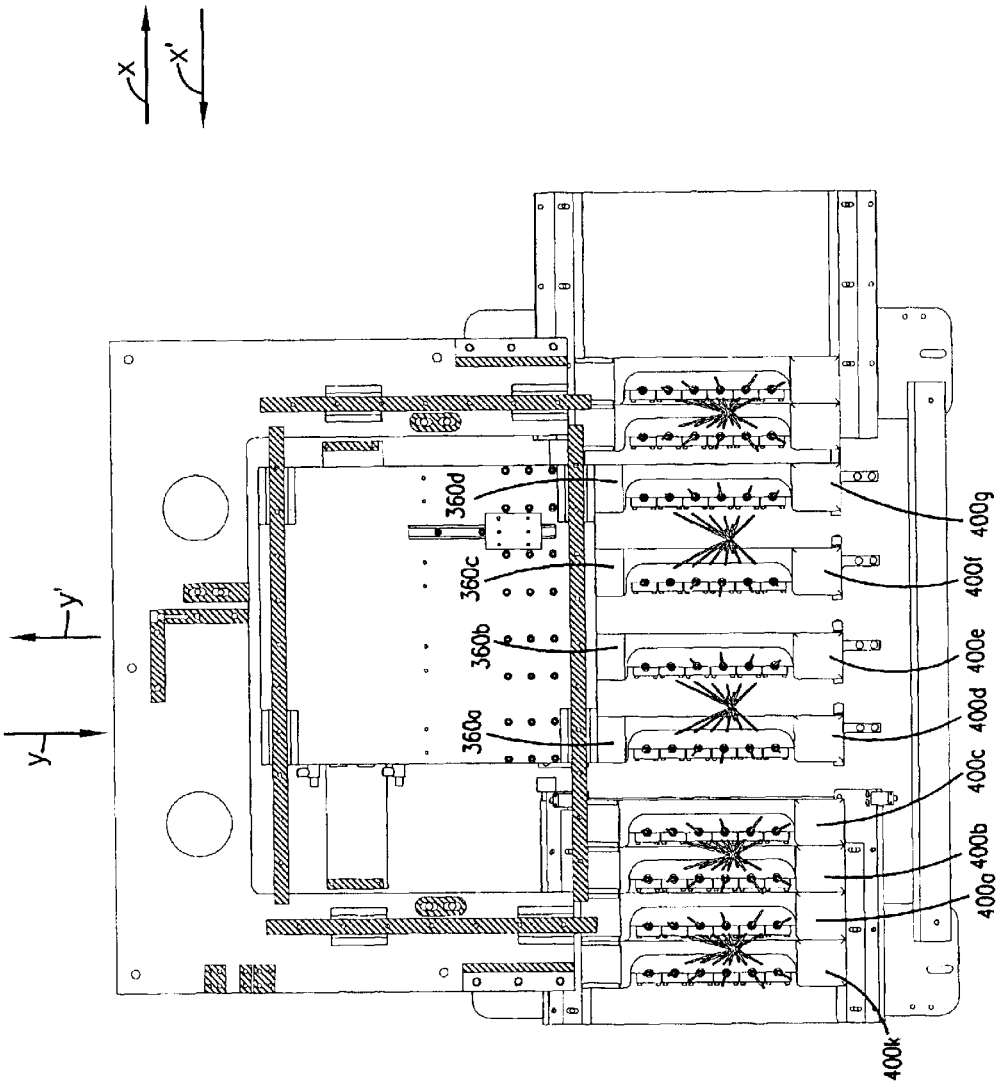

FIG. 40

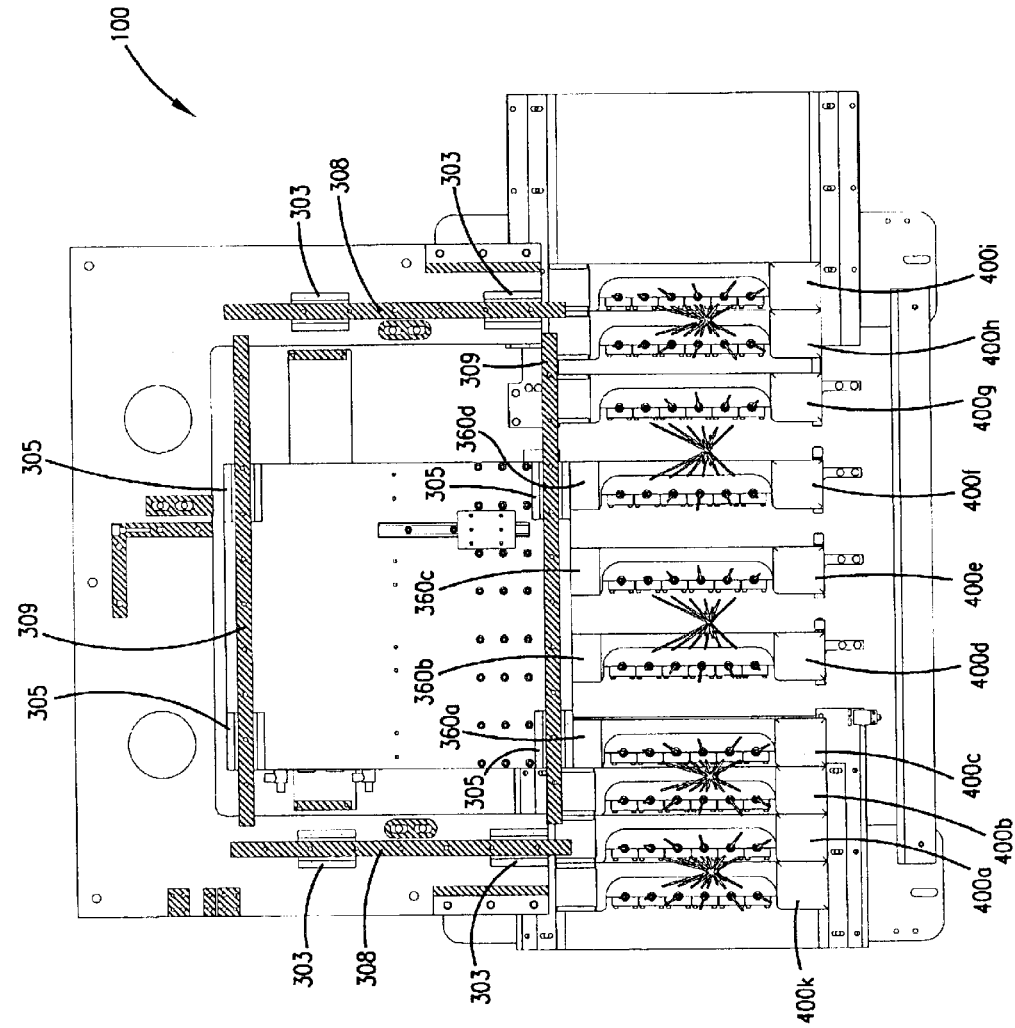

FIG. 41

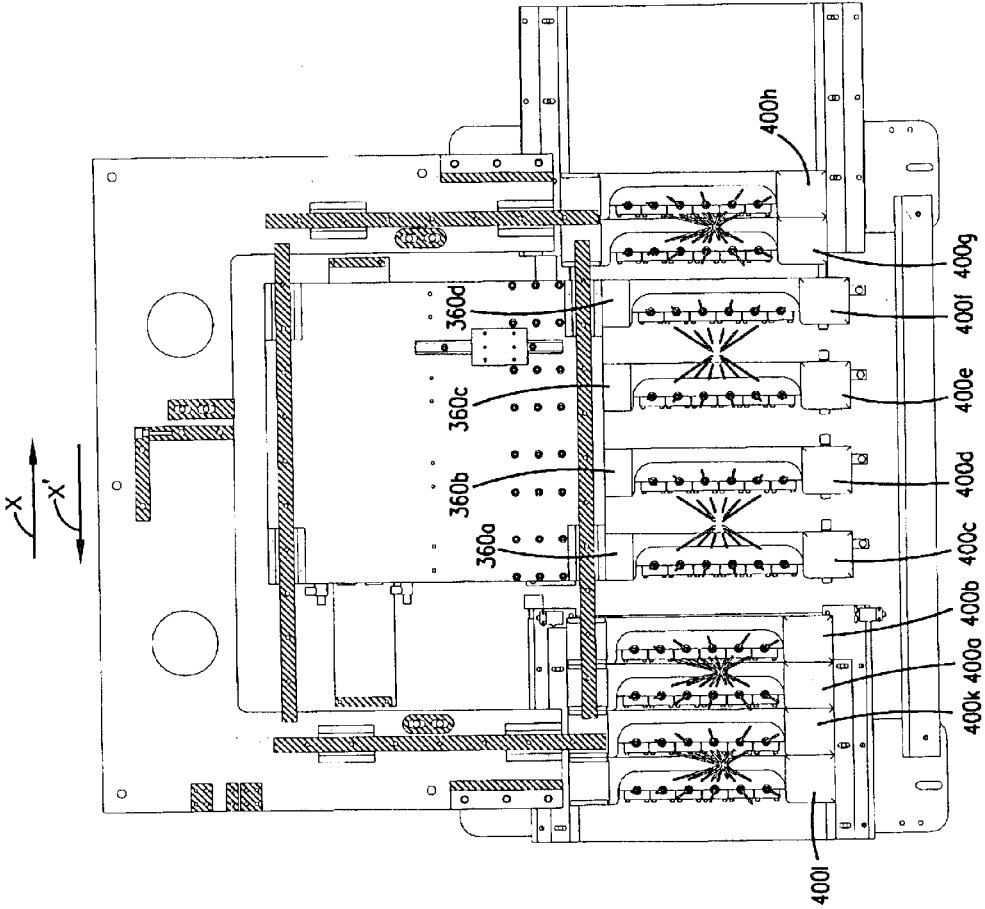

FIG. 42

## APPARATUS AND METHOD FOR POLISHING A FIBER OPTIC CONNECTOR

### FIELD OF THE INVENTION

The present invention relates generally to an apparatus and method for manufacturing fiber optic connectors. More particularly, the present invention relates to an apparatus and method for polishing fiber optic connectors to improve the performance characteristics of the connectors.

### BACKGROUND OF THE INVENTION

Fiber optic connectors are used to terminate the ends of fiber optic cables. There are many different fiber optic connector types. Example types of fiber optic connectors include FC-type, SC-type, ST-type and D4-type.

FIG. 1 shows a typical connector 10. A ferrule 12 is located inside the connector 10. The ferrule 12 is a relatively long, thin cylinder preferably made of a material such as ceramic. Other materials such as metal or plastic can also be used to make the ferrule 12. The ferrule 12 defines a central opening 14 sized to receive a fiber 16 of a given cladding diameter. An epoxy is typically placed into the opening 14 prior to inserting the fiber 16 to hold the fiber 16 in place. The ferrule 12 functions to align and center the fiber 16, as well as to protect it from damage.

Referring still to FIG. 1, the ferrule 12 is supported within a connector body 18 typically made of a material such as metal or plastic. The connector body 18 is typically bonded to fiber optic cable 20 (e.g., the cable 20 can include a reinforcing layer made of a material such as Kevlar that is affixed to the connector 18). A strain relief boot 22 protects the junction between the connector 18 and the cable 20. Two connectors are preferably interconnected through the use of an adapter 24. Adapter 24 includes a sleeve 26 sized to receive the ferrules of the connectors desired to be connected. For example, ferrule 12 of connector 10 is inserted into a first end 28 of the sleeve 26, while a ferrule (not shown) of a connector desired to be connected to the connector 10 is inserted into a second end 30 of the sleeve 26. As so inserted, the ends of the ferrules abut one another within the sleeve 26 such that their corresponding fibers are held in alignment with one another.

It is desirable to minimize the loss of signals passing through the fiber. Parameters for evaluating the performance of a connector include insertion loss and return loss. Insertion loss is the measurement of the amount of power that is transferred through a coupling from an input fiber to an output fiber. Return loss is the measurement of the amount of power that is reflected back into the input fiber. To enhance signal quality and therefore optimize insertion/return loss, it is desirable to polish an end face 13 of the ferrule 12. During the polishing process, the ferrule 12 is commonly held in a fixture, and the end 13 is pressed against an oscillating and rotating disk. Frequently, the end 13 is polished to form a spherical polished surface oriented along a plane that is perpendicular with respect to the longitudinal axis of the fiber 16. However, for some applications, the end 13 is polished to form a spherical surface aligned at an oblique angle with respect to the longitudinal axis of the fiber 13.

FIG. 2 is a block diagram showing the steps of a convention ferrule polishing technique for providing a rounded ferrule tip. During a first polishing step 70, a hackle of the fiber and residue epoxy are removed from the ferrule tip typically by a hand-sanding process or automated system

such as an epoxy removal machine. After the hackle and epoxy have been removed, the tip of the ferrule is machine polished using two or more polishing films (e.g., of varying coarseness) so as to more precisely form an apex and radius into the tip of the ferrule (see step 72). Next, the tip of the ferrule is machine polished with a final polish film as indicated by step 74. During the polishing process, an index layer is formed at the tip of the fiber within the ferrule. The index layer has undesirable optical properties. Thus, at final step 76, the tip of the ferrule is polished with a cerium oxide film causing the fiber to be recessed slightly into the ferrule a distance sufficient to remove the index layer. For some applications, the tip is recessed prior to the final polish, as disclosed, for example, in U.S. patent application Ser. No. 10/071,856, filed Feb. 8, 2002, which is hereby incorporated by reference.

### SUMMARY OF THE INVENTION

One aspect of the present invention relates to a fiber optic connector polishing apparatus and method for polishing fiber optic connectors to improve the performance characteristics of the connectors.

A variety of advantages of the invention will be set forth in part in the description that follows, and in part will be apparent from the description, or may be learned by practicing the invention. It is to be understood that both the foregoing general description and the following detailed description are exemplary and explanatory only and are not restrictive of the invention as claimed.

### BRIEF DESCRIPTION OF THE DRAWINGS

The accompanying drawings, which are incorporated in and constitute a part of the specification, illustrate several aspects of the invention and together with the description, serve to explain the principles of the invention. A brief description of the drawings is as follows:

FIG. 1 illustrates a typical prior art connector;

FIG. 2 illustrates a prior art polishing technique;

FIG. 3 is a perspective plan view of an example embodiment of a polishing apparatus made in accordance with the present invention;

FIG. 4 is front view of the example polishing apparatus of FIG. 3;

FIG. 5 is a side view of the example polishing apparatus of FIG. 3;

FIG. 6 is a top view of the example polishing apparatus of FIG. 3;

FIG. 7 is a perspective view of the polishing apparatus of FIG. 3 with various components including a cover of the drive mechanism omitted for clarity;

FIG. 7A is a cross-sectional view taken along section line CC—CC of FIG. 26 with various components including the fixtures omitted for clarity;

FIG. 8 is a front view of the polishing apparatus of FIG. 7;

FIG. 9 is a first side view of the polishing apparatus of FIG. 7;

FIG. 10 is a second side view of the polishing apparatus of FIG. 7;

FIG. 11 is a top view of the polishing apparatus of FIG. 7;

FIG. 12 is a perspective plan view of an example embodiment of a fixture shown in isolation;

FIG. 13 is a side view of the fixture of FIG. 12;

## 3

FIG. 14 is a top view of the fixture of FIG. 12;

FIG. 15 is a cross-sectional view taken along section line A—A of FIG. 14;

FIG. 16 is a first perspective plan view of an example embodiment of a polishing sub-assembly shown in isolation;

FIG. 17 is a second perspective view of the polishing sub-assembly of FIG. 16;

FIG. 18 is a front view of the polishing sub-assembly of FIG. 16;

FIG. 19 is a first side view of the polishing sub-assembly of FIG. 16;

FIG. 20 is a second side view of the polishing sub-assembly of FIG. 16;

FIG. 21 is a top view of the polishing sub-assembly of FIG. 16;

FIG. 22 is a cross-sectional view taken along section line B—B of FIG. 18 of the polishing sub-assembly;

FIG. 23 is an enlarged view of a portion of the sub-assembly shown in FIG. 22;

FIG. 24 is a cross-sectional view taken along section line C—C of FIG. 21 of the polishing sub-assembly;

FIG. 25 is an enlarged view of a portion of the polishing sub-assembly shown in FIG. 24;

FIG. 26 is a front view of a portion of the example embodiment of the polishing apparatus with the fixtures in a nested position;

FIG. 27 is a cross-sectional view taken along section line D—D of FIG. 26 of the polishing apparatus;

FIG. 28 is a cross-sectional view taken along section line D—D of FIG. 26 illustrating the gripper arms coupled to the fixtures and the fixtures moved to an un-nested position;

FIG. 29 is a cross-sectional view taken along section line D—D of FIG. 26 illustrating the fixtures in a pre-push position;

FIG. 30 is a cross-sectional view taken along section line D—D of FIG. 26 illustrating the fixtures in a post-push position;

FIG. 31 is a cross-sectional view taken along section line D—D of FIG. 26 illustrating the fixtures in position to begin the polishing cycle;

FIG. 31A is an enlarged view of a portion of the polishing sub-assembly illustrating the pad system in a raised position;

FIG. 31B is an enlarged view of a portion of the polishing sub-assembly illustrating the pad system in a lowered position;

FIG. 32 is a cross-sectional view taken along section line D—D of FIG. 26 illustrating the fixtures moved in the Y' direction;

FIG. 33 is a cross-sectional view taken along section line D—D of FIG. 26 illustrating the fixtures moved back in the Y direction to their initial position;

FIG. 34 is a cross-sectional view taken along section line D—D of FIG. 26 illustrating the fixtures moved in the Y direction;

FIG. 35 is a cross-sectional view taken along section line D—D of FIG. 26 illustrating the fixtures moved back in the Y' direction to their initial position;

FIG. 36 is a cross-sectional view taken along section line D—D of FIG. 26 illustrating the fixtures moved in the X' direction;

FIG. 37 is a cross-sectional view taken along section line D—D of FIG. 26 illustrating the fixtures moved back in the X direction to their initial position;

## 4

FIG. 38 is a cross-sectional view taken along section line D—D of FIG. 26 illustrating the fixtures moved in the X direction;

FIG. 39 is a cross-sectional view taken along section line D—D of FIG. 26 illustrating the fixtures moved back in the X' direction to their initial position;

FIG. 40 is a cross-sectional view taken along section line D—D of FIG. 26 illustrating the fixtures in the nested position;

FIG. 41 is a cross-sectional view taken along section line D—D of FIG. 26 illustrating the gripper arms indexed in the X' direction; and

FIG. 42 is a cross-sectional view taken along section line D—D of FIG. 26 illustrating the fixtures indexed in the X direction one polishing sub-assembly.

While the invention is amenable to various modifications and alternative forms, the specifics there have been shown by way of example in the drawings and will be described in detail below. It is to be understood, however, that the intention is not to limit the invention to a particular embodiment. On the contrary, the intention is to cover all modifications, equivalents and alternatives falling within the scope of the invention as defined by the appended claims.

## DETAILED DESCRIPTION

In the following detailed description, references are made to the accompanying drawings that depict various embodiments which are examples of how inventive concepts in accordance with the principles of the present disclosure may be practiced. It is to be understood that other embodiments may be utilized, and that structural and functional changes may be made without departing from the scope of the present invention.

The disclosure generally relates to a polishing apparatus for polishing end faces of fiber optic connectors (e.g. end face 13 of the fiber optic connector 10 of FIG. 1), such as the example embodiment of a polishing apparatus 100 as shown in FIGS. 3–6. The polishing apparatus 100 may generally include a support system 200 and one or more fixtures 400 configured to hold a plurality of fiber optic connectors. A drive mechanism 300 may be coupled to the support system to move the fixtures 400 in one or more directions. Also provided is a polishing sub-assembly 500 including various components to polish the plurality of fiber optic connectors held by the fixtures 400. A control panel 700 for controlling the polishing apparatus 100 may also be provided.

A detailed description is provided below of the various components comprising the example polishing apparatus 100 and a method of using the polishing apparatus 100. The description below is provided by way of example only. Other configurations and methods of use are also possible with departing from the spirit of the invention.

## I. The Support System

Referring again to FIGS. 3–6, the polishing apparatus 100 includes the example support system 200. The support system 200 generally includes a support structure 210 that is configured to support the components of the polishing apparatus 100, including the fixtures 400, the drive mechanism 300, the polishing sub-assemblies 500, and the control panel 700. Also included is a drive mechanism cover 215 covering the drive mechanism 300, as well as an electrical components housing 230 covering various electrical components used to control the polishing apparatus 100. A plurality of fixed supports 240 (e.g., adjustable feet) and wheels 245 are also provided to allow for the support and relocation of the polishing apparatus 100.

A plurality of cable supports **220** is also provided. The cable supports **220** generally function to hold an end segment of one or more fiber optic cables and allow the end segment to extend through the cable support **220** and over the fixtures **400**. As shown in FIG. **5**, this fiber optic cable **219** may include a plurality of smaller cables **221**, each being terminated by a connector, such as the connector **10**. For example, in the embodiment shown in FIG. **5**, the larger cable is maintained on a separate support (not shown) positioned adjacent each cable support **220**. An end segment **219a** of the larger cable is extended through the cable support **220**, and each of the connectors **10** of each of the smaller cables **221** contained therein are held by fixtures **400** positioned below each cable support **220**.

In the example embodiment shown, the cable supports **220** are mounted to a railway **225** and are configured to slide along the railway **225** as the fixtures **400** are moved, as described in detail below. The railway **225** may be supported separately from the polishing apparatus **100**, as is shown in the example embodiment. Alternatively, the railway **225** may be coupled to and supported by the polishing apparatus **100**.

## II. The Drive Mechanism

Referring now to FIGS. **7–11**, the cover **215** has been removed to illustrate the drive mechanism **300** with greater clarity. The drive mechanism generally includes a Y-table **302** and an X-table **304** (see FIGS. **9** and **10**). The Y-table **302** includes a Y-drive **310** and bearings **303** (see also FIGS. **27–42**) that are mounted to a flat support **250** of the support system **200**. The Y-table **302** is coupled to the Y-drive **310** and the bearings **303** so that the Y-drive **310** can move the Y-table **302** forward in a Y direction and backward in a Y' direction.

The X-table **304** is coupled to a bottom of the Y-table **302** so that the X-table **304** also moves with the Y-table **302** in the Y and Y' directions. The X-table **304** is coupled to the Y-table using bearings **305** (see FIGS. **27–42**) and includes an X-drive **315** mounted to a support **255** coupled by supports **256** to the support **250** and extending over the X and Y tables **302** and **304**. An X-drive shaft **319** (see FIGS. **7**, **7A**, and **27**) extends from the X-drive **315** through an aperture **320** (see FIG. **11**) formed in the Y-table **302** and is coupled to a bearing **316** that rides on a rail **317** coupled to the X-table **304**.

The X-drive **315** can, through the X-drive shaft **319**, cause the X-table **304** to move in an X direction and opposite X' direction. When the Y-drive causes the table to move in the Y and Y' directions, the X-table **304** also moves in the Y and Y' directions because the bearing **316** rides along the rail **317**, allowing the X-table **304** to move in the Y and Y' directions while the X-drive shaft **319** and the X-drive **315** remains stationary or moves in the X and X' directions.

The X-table **304** is, in turn, coupled to each of the plurality of fixtures **400**. In this configuration, the drive mechanism **300** can move the fixtures **400** in both the X, X', Y, and Y' directions or a combination thereof.

Both the Y-drive **310** and the X-drive **315** are coupled directly to the support system **200** and are mounted in a fixed position (i.e. the Y-drive is fixedly mounted to the support **250** and the X-drive is fixedly connected to the support **255**). This may be advantageous for several reasons, including: (1) any supporting components, such as electrical cords (if the Y and X-drivers are electrically driven, as is the case in the example embodiment shown) or air housing (if the Y and X-drives are pneumatically driven) are held in a stationary position, thereby eliminating any flexure which may cause stress and subsequent failure; and (2) fixedly-coupling the

drives may reduce or eliminate possible fluctuations in movement in the Y, Y', X, and X' directions due to vibration and/or other disturbances transmitted to the Y and X-drives.

## III. The Fixtures

Referring now to FIGS. **12–15**, each fixture **400** includes a plurality of connector locations **410** sized to each receive a body of a fiber optic connector (e.g., connector body **18** of the fiber optic connector **10** shown in FIG. **1**) and allow an end face of each fiber optic connector (e.g., end face **13**) to extend through each connector location **410**. In the illustrated embodiment, each fixture **400** includes six connector locations **410** so that each fixture **400** can hold six connectors. In alternative embodiments, the fixture can be configured with more or fewer connector locations to hold more or fewer connectors, such as, for example, three connector locations to hold three connectors.

Each fixture **400** includes a main body **415**. A plurality of moveable connecting slates **417** is coupled to the main body **415**. The slates **417** cooperate with the main body **415** to define a plurality of nests **419** for receiving connectors **10**. In the embodiment of FIG. **14**, each nest **419** includes a half-nest **419a** defined by the main body **415** and a half-nest **419b** defined by a corresponding slate **417**.

Each connecting slate **417** is coupled to the main body **415** using two fasteners (e.g., screws **420**) threaded within openings **421** defined by the main body **415**. Each screw **420** includes one or more “belville” washers to provide clamping force and compliance to allow the clamps to open. In addition, small metallic balls (not shown) are positioned in apertures **422** formed in a surface **424** of the main body **415** so that, when the connecting slates **417** are coupled to the main body **415**, the balls are sandwiched between the main body **415** and the connecting slates **417**. In this configuration, the screws **420** and the balls allow the connecting slates **417** to pivot with respect to the main body **415** and thereby increase the opening of the connector locations **410** to facilitate the introduction and removal of each fiber optic connector into and out of each fixture **400**.

Alternative structures can also be used to hold each connector body within the fixture. For example, instead of clamping the ferrule of a connector, as describe above, another portion of the connector can be held to maintain the connector at a known orientation within the fixture. For example, the fixtures can be configured to clamp on the boot of each connector, and each fixture can include a close-tolerance hole through which the end face of each ferrule extends to be polished. This may be advantageous in that only a portion of the ferrule, including the end face, extends through the fixture to the polishing sub-assembly, so that the remainder of the connector body is isolated from any debris generated during polishing. In another embodiment, both an upper portion of a connector, such as the boot, as well as the ferrule can be clamped by the fixture to hold the connector in place during polishing. Other configurations are also possible.

Referring now to FIGS. **19**, **20**, and **22**, each fixture **400** also includes a gripping feature **430** positioned on one end of the fixture **400**. The gripping feature **430** is shaped to allow a gripping arm **360**, which is mounted to the X-table **304**, to grab and manipulate each fixture **400**. The gripping feature **430** includes first and second opposing projections **432** and **434** that fit into a complementary geometry of the gripping arm **360**. The gripper arm **360** further includes an air cylinder **364** coupled to the gripper arm **360** which causes a piston **362** to project against the projection **434** on the fixture **400**, thereby further holding the fixture **400** in the gripper arm **360** and level with the polishing sub-assemblies described below.

In addition, the fixture **400** includes resting surfaces **435** used to support the fixture **400** when it is in a nested position, as described further below.

The fixture **400** is further designed to be used to hold the connectors **10** throughout other processes besides polishing, such as, for example, epoxy dispense, curing, and cleaving.

#### IV. The Polishing Sub-Assemblies

Referring now to FIGS. **16–24**, an example embodiment of one polishing sub-assembly **500** is shown. The polishing sub-assembly **500** may generally include a pad system **510** (shown in FIG. **22**), a polishing film system **540** (shown in FIG. **17**), a fluid injection system **570** (shown in FIG. **23**), and an optional rinsing system **580** (shown in FIG. **16**). A circular tube guide **590** may also be provided to guide various wires and supply tubes, such as, for example, electrical wires, pressurized air tubes, and fluid tubes, into and out of the polishing sub-assembly **500**.

Although only a single polishing sub-assembly **500** is described in detail below, a plurality of polishing sub-assemblies **500** may be included with the polishing apparatus **100**. In the illustrated embodiment, four polishing sub-assemblies are provided so that four fixtures including connectors contained therein can be processed at one time. In alternative embodiments, more or fewer sub-assemblies can be provided to handle more or fewer fixtures at one time, such as, for example, between one and ten polishing sub-assemblies.

Detailed descriptions of examples systems comprising the polishing sub-assembly **500** are provided below. As previously stated, other configurations for the sub-assembly **500** are also possible.

##### (a) The Pad System

The pad system **510** is shown, for example, in FIGS. **22–25**. The pad system **510** generally includes a plurality of pads **511** and corresponding pad shafts **512**, preferably one pad **511** and one pad shaft **512** for each connector location **410** of each fixture **400**. Each pad **511** is coupled to a first end of the pad shaft **512**. A second end of the pad shaft **512** is coupled to a piston **515** positioned in a bore **516**. As air is applied to the piston **515** in the shaft **516**, the shaft **512** and attached pad **511** are moved in a vertical direction upward towards a connector held in the fixture **400** above the pad **511** (see FIG. **31A**). Guides **513** and **514** assure that the pad is held in a known orientation (e.g., vertical) as it moves vertically up towards the connectors.

As described below, air can be applied in the bore **516** until the pad **511** moves vertically upwards to compress a polishing film against the end face **13** of each connector **10** with a desired force (e.g.,  $\frac{3}{4}$  lb. for polishing FC or SC connectors according to the example embodiment shown). As the air pressure in the bore **516** is reduced, the shaft **512** and attached pad **511** may move in an opposite direction back towards a resting position, thereby disengaging the pads **511** from the connectors **10** (see FIG. **31B**).

Each bore **516** on the polishing sub-assembly **500** is fed air from a common air manifold **517** (see FIG. **16**). Therefore, each bore **516** preferably receives the same air pressure provided by the air manifold. In this manner, each pad **511** may engage each end face **13** at an equal force regardless of the position of each end face **13** with respect to each pad **511**. In an alternative embodiment, pressure provided to each pad can be independently controlled, if desired.

In the illustrated embodiment, the pad system **510** utilizes a system of linear bearings so that each pad shaft and pad can be moved upwardly and downwardly with respect to the remainder of the polishing sub-assembly **500**. Alternatively,

other systems allowing the necessary movement of the pad shaft and pad can be used, such as, for example, a parallel linkage mechanism. This alternate type of mechanism may be advantageous to reduce the friction associated with the movement of the pad shaft.

Optionally, a system (not shown) can be provided to regulate the rate of accent of the pads towards the ferrules of the connectors. For example, each pad **511** or pad shaft **512** can be coupled to a cam that rotates as the pad moves upward to contact a ferrule. The cam can be regulated to control the rate of accession. After the pad contacts the ferrule and polishing begins, the pad and/or pad shaft is released from the cam. This may be advantageous so that the pads contact the ferrules with at a given rate.

In the example embodiment shown, the pads **511** are made of Neoprene. Other materials may also be used, such as Buna N, viton, urethane, silicone, etc. or any other material that can withstand deionized water or other fluids used and can be manufactured with the desired durometer (i.e., stiffness) for a given polishing application.

##### (b) The Polishing Film System

The polishing film system **540**, as shown in FIGS. **19–22**, generally includes polishing film **542**, a spool **546**, a used film collection bin **544**, a pincher roller **548**, and a plurality of rollers. New polishing film is provided on the spool **546**. The polishing film **542** is directed around a tension roller **555**, with tension being maintained by tension shaft **551** (see FIG. **19**), and through a series of rollers **560**, **561**, and **562**. Preferably, the polishing film **542** travels over roller **560**, under roller **561**, and over roller **562**. This configuration is preferable so that any fluid maintained on the polishing film **542** (as described below) falls into a drip tray **563** rather than running down the polishing film **542** and onto the new polishing film maintained on the spool **546** or into the used film collection bin **544**. In one example embodiment, 3M Imperial Diamond Lapping Film with a one micron grit manufactured by Minnesota Mining and Manufacturing of St. Paul, Minn. was used as the polishing film **542**.

The polishing film **542** then travels over the plurality of pads **551** and then over and under a second series of rollers **564**, **565**, and **566**, with a trap **567** functioning similarly to the drip tray **563**. The polishing film **542** then runs through the pincher roller **548** that engages the polishing film **542** with opposing rollers **552** and **553** driven by motor **569** and belt **568** used to index the polishing film, as described below. This indexing can be configurable, as desired, to control the amount of polishing film reuse. Finally, the used polishing film falls into the used film collection bin **544**. Alternatively, instead of the film collection bin **544**, a second spool can also be used to maintain the used polishing film prior to discarding it.

Polishing the end face **13** of a connector **10** can be accomplished by compressing the end face **13** against the polishing film **542**, such as with the pad system **510**. With the connector **10** compressed against the polishing film **542**, the connector **10** can be moved in a sequence of patterns over the polishing film **542**, thereby polishing the end face **13**. In addition, as described below, a plurality of polishing sub-assemblies **500** may be provided, with each polishing sub-assembly having a difference coarseness of polishing film **542**. For example, coarse, medium, and fine polishing grades of polishing film can be used. In this configuration, the end face **13** can be sequentially polished with the different grades of polishing film to a desired polished state.

##### (c) The Fluid Injection System

Referring now to FIGS. **22–25**, the fluid injection system **570** is shown. As shown in FIG. **23**, the fluid injection



system **570** includes a plurality of jet bars **572** positioned to extend parallel to a longitudinal direction of the fixtures **400** between adjacent connectors and over the polishing film **542**. Each jet bar **572** includes a series of jets **574** formed in the bar **572**. The jets **574** deliver a series of streams of de-ionized water onto the polishing film **542**. In the illustrated embodiment, each jet bar **572** is configured to move as each fixture is moved to polish the connectors contained therein. In alternative embodiments, each jet bar **572** can be fixed in place.

The de-ionized water functions to facilitate the movement of the end faces **13** of each connector **10** over the polishing film **542**, as well as to clean and remove debris from the polishing film **542** and the end faces **13** of the connectors **10**. In alternative embodiments, other types of fluid such as a slurry of alcohol and water mixes may be used in place of the de-ionized water.

In the example embodiment illustrated, the water is injected throughout the polishing cycle. However, fluid injection system **570** may be fully programmable to allow the water to be turned on and off during each cycle as desired.

As shown particularly in FIGS. **23** and **25**, each jet bar **572** further includes alignment pins **576** positioned on opposite sides and extending below the level of the polishing film **542**. The alignment pins **576** function to hold the polishing film **542** onto each pad **511** as polishing occurs.

As shown in FIG. **23**, the fluid injection system **570** further includes a series of steel plates **578** positioned between each pad **511**. Each plate **578** includes a contact surface **579** of limited surface area. When a polishing cycle is complete and the pads system **510** with pads **511** is allowed to move vertically downward to a rest position (see FIG. **31B**), the contact surface **579** of each plate **578** extends above each pad **511** and makes contact and supports the polishing film **542**. The small contact area between the plates **578** and the polishing film **542** can be advantageous in that if the film **542** is left in contact with the plates **578** for an extended period of time (e.g., when the polishing apparatus is not used for a period of time), there is little surface area of each plate **578** on which the polishing film **542** can adhere.

#### (d) The Rinsing System

Referring now to FIGS. **16** and **25**, in addition to the fluid injection system **570**, the optional rinsing system **580** may also be provided on the polishing sub-assembly **500**, if desired. The rinsing system **580** generally includes a roller **582** and a fluid supply **584** (see FIG. **16**), in the example embodiment de-ionized water. The roller **582** may be made of any compliant material that becomes saturated with water, such as, for example, a foam material.

The fluid supply **584** runs through the roller **582** and small holes in the supply **584** positioned within the roller **582** allow the water to escape outwardly into the roller **582**, thereby saturating the roller **582** with de-ionized water. In this manner, the roller **582** may be maintained in a saturated state. In addition, the roller **582** may be mounted so that the roller **582** rotates about the supply **584**.

The roller **582** is positioned adjacent the pads **511** and fixtures **400** so that, as described below, when a fixture **400** is moved from one polishing sub-assembly to another, the end faces **13** of the connectors **10** maintained in each fixture **400** are caused to pass over and rub against the saturated roller **582**, thereby causing the rollers **582** to spin and any debris on the end faces **13** of the connectors to be removed. In an alternative embodiment, each fixture **400** may be passed back and forth over the roller **582** multiple times to

more thoroughly clean the end faces **13**. In this manner, the end faces **13** can be maintained in a clean state.

In alternative embodiments, other configurations besides a roller may also be used, such as a stationary rinsing pad.

#### V. The Control Panel

The control panel **700**, as shown generally in FIGS. **3-6**, functions to control the operation of the polishing apparatus **100**, as described below. In addition to starting and stopping the apparatus **100**, the control panel **700** may also be used to change polishing times, speeds, patterns, and other configurable parameters. In addition, the control panel **700** may include a computer-driven graphical user interface (GUI) to allow for ease of use. The GUI may include preset operational menu to allow a user to input different cable fiber types or product specifications to access pre-programmed polishing cycles. An emergency stop button **702** (see FIG. **5**) may also be included to stop the apparatus **100**, if needed.

#### VI. Methods of Use

The polishing apparatus **100** may be used according to the method described below and illustrated in the cross-sectional views of FIGS. **27-42** taken along line D—D of FIG. **26**. Throughout the steps provided below, movement of the Y-table **302** and the X-table **304** will be described and shown.

Reference throughout the method illustrated in FIGS. **27-42** will be made generically to various like components using a generic reference number, while reference to a specific components will be made using a reference number qualified with a letter. For example, generic reference to all fixtures illustrated in FIGS. **27-42** will be made using **400**, while reference to a specific fixture will be made using, for example, **400a**.

Additional steps to those provided below, as desired, may also be added, and one or more of the steps may be omitted without departing from the spirit of the invention. Although a series of discrete steps are illustrated in FIGS. **27-42**, the motion of the polishing apparatus **100** may be continuous and may exhibit a continuum of positions as the polishing apparatus **100** moves through the various steps.

#### (a) The Fixtures Are Guided to the Polishing Apparatus

Referring to FIG. **27**, in a first step, one or more fixtures **400** are guided to the example polishing apparatus **100**. The fixtures may be guided manually, such as by hand-feeding the fixtures into the machine, or automatically, such as by a conveyor system (not shown). In the example embodiment shown in FIG. **27**, the fixtures **400a**, **400b**, and **400c** are positioned at a resting station prior to polishing by the apparatus **100**. In addition, the fixtures **400i**, and **400j** have already completed the polishing by the apparatus **100** and are awaiting transport away, either manually or automatically.

The fixtures **400e**, **400f**, **400g**, and **400h** are currently positioned over a respective polishing sub-assembly **500a**, **500b**, **500c**, and **500d** in a nested state. In this nested state, as best illustrated in FIGS. **19** and **20**, the resting surfaces **435** of each fixture **400** are resting on surfaces **280** and **281** of the support system **200**. The surfaces **280** and **281** fully support the fixtures **400e**, **400f**, **400g**, and **400h** so that gripper arms **360a**, **360b**, **360c**, and **360d** can fully release the fixtures **400e**, **400f**, **400g**, and **400h**.

#### (b) The Fixtures Are Grasped and Indexed Over One Polishing Sub-Assembly

Referring now to FIGS. **28-31**, a new fixture **400k** has been added to the line of fixtures waiting to enter the polishing apparatus **100** and the fixture **400j**, which had already completed polishing, has been removed, either manually or automatically. Referring now to FIG. **28**, the

fixtures **400d**, **400e**, **400f**, and **400g** have been grasped by the gripper arms **360a**, **360b**, **360c**, and **360d**, respectively, and the Y-table has been moved forward in the Y direction, thereby moving the fixtures **400d**, **400e**, **400f**, and **400g** forward. This can be seen by noting the relative positions of fixtures **400d**, **400e**, **400f**, and **400g** with respect to the other fixtures **400k**, **400a**, **400b**, **400c**, **400h**, and **400i**. In addition, this movement can also be noted by examining the relative positions of the bearings **303** with respect to the rails **308**.

In FIG. 29, the grasping arms **360** have moved fixtures **400d**, **400e**, **400f**, and **400g** in the X direction towards the fixture **400h**. In the example position shown, the fixture **400g** is positioned immediately adjacent the fixture **400h** in a pre-push configuration.

In FIG. 30, the grasping arms **360** move the fixtures **400d**, **400e**, **400f**, and **400g** further in the X direction, causing the fixture **400g** to contact and push the fixture **400h**, which has already undergone polishing, further along in the X direction and out of the way of the polishing (i.e. a post-push position).

In FIG. 31, the grasping arms **360** have moved the fixtures **400d**, **400e**, **400f**, and **400g** back in the X' direction, thereby positioning the fixtures **400d**, **400e**, **400f**, and **400g** directly over the four respective polishing sub-assemblies **510a**, **510b**, **510c**, and **510d**.

During indexing of the fixtures, the pad system is in a lowered position, as shown in FIG. 31B.

(c) The Pad System is Raised

With the fixtures **400d**, **400e**, **400f**, and **400g** positioned over their respective polishing sub-assemblies, a plurality of pads **511** of each pad system **510** of each sub-assembly **500** are raised using air pressure (see FIG. 31A), as described above. As the pads **511** are raised, the polishing film **542**, positioned to pass over the pads **511**, is also raised and pressed against the end faces **13** of the ferrule **12** of each connector **10** held by each of the fixtures **400d**, **400e**, **400f**, and **400g**. As described previously, each pad **511** acts separately to apply equal force to each end face **13** of each ferrule **12**. In this configuration, the polishing film **542** is held by each pad **511** and biased against each connector **10** (such as is shown in, for example, FIGS. 23 and 25).

(d) The Polishing Cycle

Referring now to FIGS. 32–39, with the fixtures **400d**, **400e**, **400f**, and **400g** positioned over the polishing sub-assemblies and the pad system **510** and polishing film **542** pressed against the end face **13** of each connector **10**, polishing is commenced. In one embodiment, polishing is accomplished by moving each fixture **400** along a two-dimensional path, thus causing the end face **13** of each the connector **10** to ride along the polishing film **542** and thereby be polished.

Referring to FIG. 32, a first step of a polishing cycle may include moving the fixtures **400d**, **400e**, **400f**, and **400g** in the Y' direction a given amount. In the example embodiment, this amount is approximately ½ inch, although other amounts can also be used as desired. In FIG. 33, the fixtures **400d**, **400e**, **400f**, and **400g** are moved in the Y direction back to their initial position. In FIGS. 34 and 35, the fixtures **400d**, **400e**, **400f**, and **400g** are moved first in the Y direction a given amount (for example, ½ inch) (see FIG. 34) and then are moved back in the Y' direction to their initial position (see FIG. 35).

In FIGS. 36 and 37, the fixtures **400d**, **400e**, **400f**, and **400g** are moved first in the X' direction a given amount (see FIG. 36) and then are moved back in the X direction to their initial position (see FIG. 37). In FIGS. 38 and 39, the fixtures

**400d**, **400e**, **400f**, and **400g** are moved first in the X direction a given amount (see FIG. 38) and then are moved back in the X' direction to their initial position (see FIG. 39).

The movement illustrated in FIGS. 32–39 can constitute a single polishing cycle. This polishing cycle can be repeated a number of times, as desired, to polish the end face **13** of each of the plurality of connectors **10** held in each fixture **400**. In addition, other sequences and cycles are also possible. In an example embodiment, the polishing cycle is a combination of motion in the X and Y directions following a spiraling circular path at a constant speed. The shape of the path is fully programmable, as are the speeds, accelerations, and directions of the polishing cycle. Furthermore, the pad force and the fluid injection can also be controlled and altered during the polishing cycle. A polishing cycle can be selected, as desired, to polish each connector **10** to meet certain specifications such as, for example, radius of curvature, apex offset, fiber height, surface finish, insertion loss, and return loss.

(e) The Pad System is Lowered and the Polishing Film is Indexed

When the polishing cycle is complete, the pad system **510** including the plurality of pads **511** are lowered (FIG. 31B), and the polishing film **542** also lowers with the pads **511**. The polishing film **542** can then be indexed by the pincher roller **548** so that fresh polishing film is positioned over the pad system **510** for the next polishing cycle.

(f) The Fixtures are Docked in the Nest

Concurrent with or subsequent to the previous step, the fixtures **400d**, **400e**, **400f**, and **400g** are moved in the Y' direction. The gripper arms **360** then release each fixture, thereby docking the fixtures in the nest as shown in FIG. 40.

(g) The Gripper Arms are Indexed

The gripper arms **360** (without the fixtures) are then indexed in the X' direction so that the gripper arm **360a** is positioned to grip the fixture **400c**, the gripper arm **360b** is positioned to grip the fixture **400d**, the gripper arm **360c** is positioned to grip the fixture **400e**, and gripper arm **360d** is positioned to grip the fixture **400f**, as is shown in FIG. 41. The gripper arms **360a**, **360b**, **360c**, and **360e** then grip the fixtures **400c**, **400d**, **400e**, and **400f**, respectively.

(h) The Rinsing System is Activated

If the rinsing system **580** is provided, it is activated so that de-ionized water flows through and saturates the roller **582**.

(i) The Fixtures Are Indexed Over One Polishing Sub-Assembly

Similar to step (b) described above, the fixtures **400c**, **400d**, **400e**, and **400f** are then indexed in the X direction one polishing sub-assembly **500**, as shown in FIG. 42. As each fixture **400** passes between adjacent polishing sub-assemblies **500**, the end face **13** of the ferrule **12** of each connector **10** is caused to contact the roller **582**, thereby removing any debris for each end face **13**. In one embodiment, each fixture **400** is passed back and forth over the roller **582** multiple times to further clean the end faces **13**. Once the fixtures have passed over the roller **582**, the flow of de-ionized water into the rinsing roller **582** is terminated.

With the fixtures **400c**, **400d**, **400e**, and **400f** positioned as shown in FIG. 42, a new polishing cycle, such as that described in steps (c)–(f) above, can be initiated.

Having described aspects and example embodiments of the present invention, modifications and equivalents of the disclosed concepts may readily occur to one skilled in the art. For example, while the fixtures illustrated herein are configured to hold connectors and associated ferrules in a vertically upright orientation, it will be appreciated that the

13

fixtures could also be oriented so as to each hold a ferrule at an oblique angle relative to a polishing surface. However, it is intended that such modifications and equivalents be included within the scope of the claims that are appended hereto.

What is claimed is:

1. A fiber optic polishing apparatus comprising:

- a support system;
- a polishing sub-assembly coupled to the support system including a plurality of pads, wherein each pad of the plurality of pads travels independently in a vertical direction;
- a fixture including a plurality of connector locations configured to hold the plurality of fiber optic connectors, the fixture being positioned adjacent to the plurality of pads so that an end surface of each of the plurality of fiber optic connectors is held in contact with a corresponding pad of the plurality of pads; and
- a drive mechanism coupled to the support system to move the fixture in at least two-dimensions to polish the end surface of each of the plurality of fiber optic connectors.

2. The fiber optic polishing apparatus of claim 1, further comprising a controller coupled to the drive mechanism to control movement of the drive mechanism.

3. The fiber optic polishing apparatus of claim 2, wherein the drive mechanism moves the fixture in a pre-determined pattern.

4. The fiber optic polishing apparatus of claim 1, wherein the plurality of pads includes one pad for each of the plurality of connector locations in the fixture.

5. The fiber optic polishing apparatus of claim 4, further comprising a web polishing film configured to pass over the plurality of pads, the web polishing film being indexed by a pincher roller.

6. The fiber optic polishing apparatus of claim 5, wherein each pad of the plurality of pads travels independently vertically to bias the web polishing film against each of the plurality of fiber optic connectors in the fixture.

7. The fiber optic polishing apparatus of claim 5, further comprising:

- a fluid injection module configured to direct fluid onto atop surface of a portion of the web polishing film positioned over the plurality of pads; and
- a rinsing module including a pressurized fluid-saturated roller positioned adjacent the plurality of pads to rub against a face of each of the plurality of fiber optic connectors to remove debris.

8. The fiber optic polishing apparatus of claim 1, wherein the fixture is a first fixture and the polishing sub-assembly is a first polishing sub-assembly, and wherein the apparatus further comprises:

- a second polishing sub-assembly coupled to the support system including a plurality of pads; and
- a second fixture including a plurality of connector locations configured to hold a plurality of fiber optic connectors, wherein the second fixture is positioned adjacent to the plurality of pads of the second polishing sub-assembly so that an end surface of each of the

14

plurality of fiber optic connectors is held in contact with a corresponding pad of the plurality of pads at a predetermined angle.

9. The fiber optic polishing apparatus of claim 8, wherein the drive mechanism simultaneously moves the first and second fixtures to polish the end surface of each of the plurality of fiber optic connectors held in the first fixture to a first polished state and to polish the end surface of each of the plurality of fiber optic connectors held in the second fixture to a second polished state.

10. The fiber optic polishing apparatus of claim 1, wherein each pad of the plurality of pads is aligned in a plane with respect to each other pad of the plurality of pads to create a row of pads.

11. A fiber optic polishing apparatus comprising:

- a support system;
- a fixture attached to the support system including a plurality of connector locations configured to hold a plurality of fiber optic connectors; and
- a polishing sub-assembly coupled to the support system including a plurality of pads each corresponding to a fiber optic connector from the plurality of connectors, wherein each of the plurality of pads travels independently to exert a desired force against an end face of each corresponding fiber optic connector of the plurality of fiber optic connectors.

12. The fiber optic polishing apparatus of claim 11, further comprising a web polishing film configured to pass over the plurality of pads, the web polishing film being indexed by a pincher roller.

13. The fiber optic polishing apparatus of claim 12, further comprising:

- a fluid injection module configured to direct fluid onto a top surface of a portion of the web polishing film positioned over the plurality of pads; and
- a rinsing module including a pressurized fluid-saturated roller positioned adjacent the plurality of pads to rub against a face of each of the plurality of fiber optic connectors to remove debris.

14. The fiber optic polishing apparatus of claim 11, wherein the fixture is a first fixture and the polishing sub-assembly is a first polishing sub-assembly, and wherein the apparatus further comprises:

- a second polishing sub-assembly coupled to the support system including a plurality of pads; and
- a second fixture including a plurality of connector locations configured to hold a plurality of fiber optic connectors, wherein the second fixture is positioned adjacent to the plurality of pads of the second polishing sub-assembly so that an end surface of each of the plurality of fiber optic connectors is held in contact with a corresponding pad of the plurality of pads at a predetermined angle.

15. The fiber optic polishing apparatus of claim 11, wherein each pad of the plurality of pads is aligned in a plane with respect to each other pad of the plurality of pads to create a row of pads.